

ITEM	DESCRIPTION	DATE	BY
01	PROJECT DESCRIPTION: STACKED TOWNHOMES, MCLLEOD MANOR PROJECT NO. 2021-01	2021-06-08	DL
02	MAJOR OCCUPANCY CLASSIFICATION: GROUP C RESIDENTIAL OCCUPANCY	9.10.2	DL
03	SUBMITTED MAJOR OCCUPANCY: N/A	9.10.2.3	DL
04	BUILDING AREA (EQUIPMENT ON THE SITE): BUILDING 'A' 425.61 m ² BUILDING 'B' 425.61 m ² BUILDING 'C' 274.22 m ²	[A]1.1.2	DL
05	GROSS FLOOR AREA (EQUIPMENT ON THE SITE): BUILDING 'A' 1469.34 m ² BUILDING 'B' 1471.28 m ² BUILDING 'C' 1084.29 m ²	[A]1.1.2	DL
06	MEZZANINE(S) AREA m ² : ONE NOT APPLICABLE	9.10.4.1	DL
07	BUILDING HEIGHT (F STORIES): ABOVE GRADE 3 BELOW GRADE 1 (GARAGE)	9.10.4	DL
08	NUMBER OF STORIES/ACCESS ROUTES: BUILDING 'A' 2 STORIES BUILDING 'B' 1 STORIES BUILDING 'C' 1 STORIES	9.10.20	DL
09	SPRINKLER SYSTEM PROPOSED: N/A	9.10.2.4	DL
10	FIRE ALARM REQUIRED: YES <input type="checkbox"/> NO <input type="checkbox"/>	9.10.18.2	DL
11	WATER SPRINKLE SYSTEM'S ASSAULT: YES <input type="checkbox"/> NO <input type="checkbox"/>	9.10.18	DL
12	PERMITTED CONSTRUCTION: YES <input type="checkbox"/> NO <input type="checkbox"/>	9.10.6	DL
13	POST DANGER BUILDING: YES <input type="checkbox"/> NO <input type="checkbox"/>	[A]1.1.2.2(2)	DL
14	TOTAL OCCUPANCY LOAD: 166 PERSONS (AS PER 2 REFERRAL OCCUPANCY LOAD)	3.1.1.7	DL

BLDG. 'A'	BLDG. 'B'	BLDG. 'C'
14	14	14
15	15	15
16	16	16
17	17	17
18	18	18
19	19	19
20	20	20

STANDARD	REQUIREMENT	COMPLIANCE
1.1	PROFESSIONAL ENGINEER AND ARCHITECT REQUIRED	YES
1.2	LOCATION OF FIRE HAZARD, FIRE ACCESS ROUTES BY OTHERS, FIRE HAZARD	YES
1.3	TO BE LOCATED WITHIN 30.0 M OF FIRE HAZARD	YES
1.4	SEPARATION AND FIRE RESISTANCE RATING	YES
1.5	REFER TO FL/MALL SCHEDULE FOR 93.0 OR U.C. LISTENS WHETHER RATINGS ARE REQUIRED.	YES

STANDARD	REQUIREMENT	COMPLIANCE
1.1	PROFESSIONAL ENGINEER AND ARCHITECT REQUIRED	YES
1.2	LOCATION OF FIRE HAZARD, FIRE ACCESS ROUTES BY OTHERS, FIRE HAZARD	YES
1.3	TO BE LOCATED WITHIN 30.0 M OF FIRE HAZARD	YES
1.4	SEPARATION AND FIRE RESISTANCE RATING	YES
1.5	REFER TO FL/MALL SCHEDULE FOR 93.0 OR U.C. LISTENS WHETHER RATINGS ARE REQUIRED.	YES

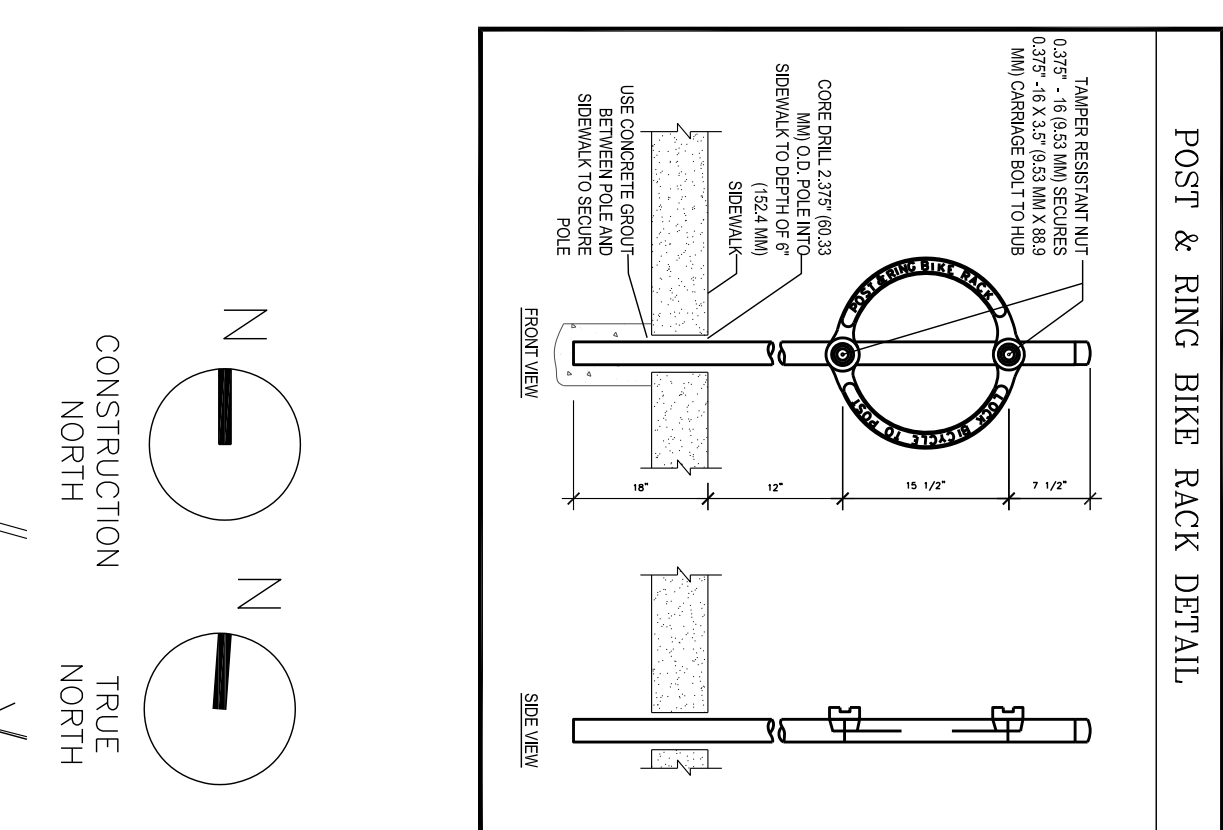

NO.	REVISION	DATE	BY
1	REVISION COMMENTS	NOV. 03/2022	DL
2	FOR ZONING AMENDMENT APPLICATION	DEC. 14/2022	DL
3	RESUBMISSION	JUN. 06/2023	DL/RF

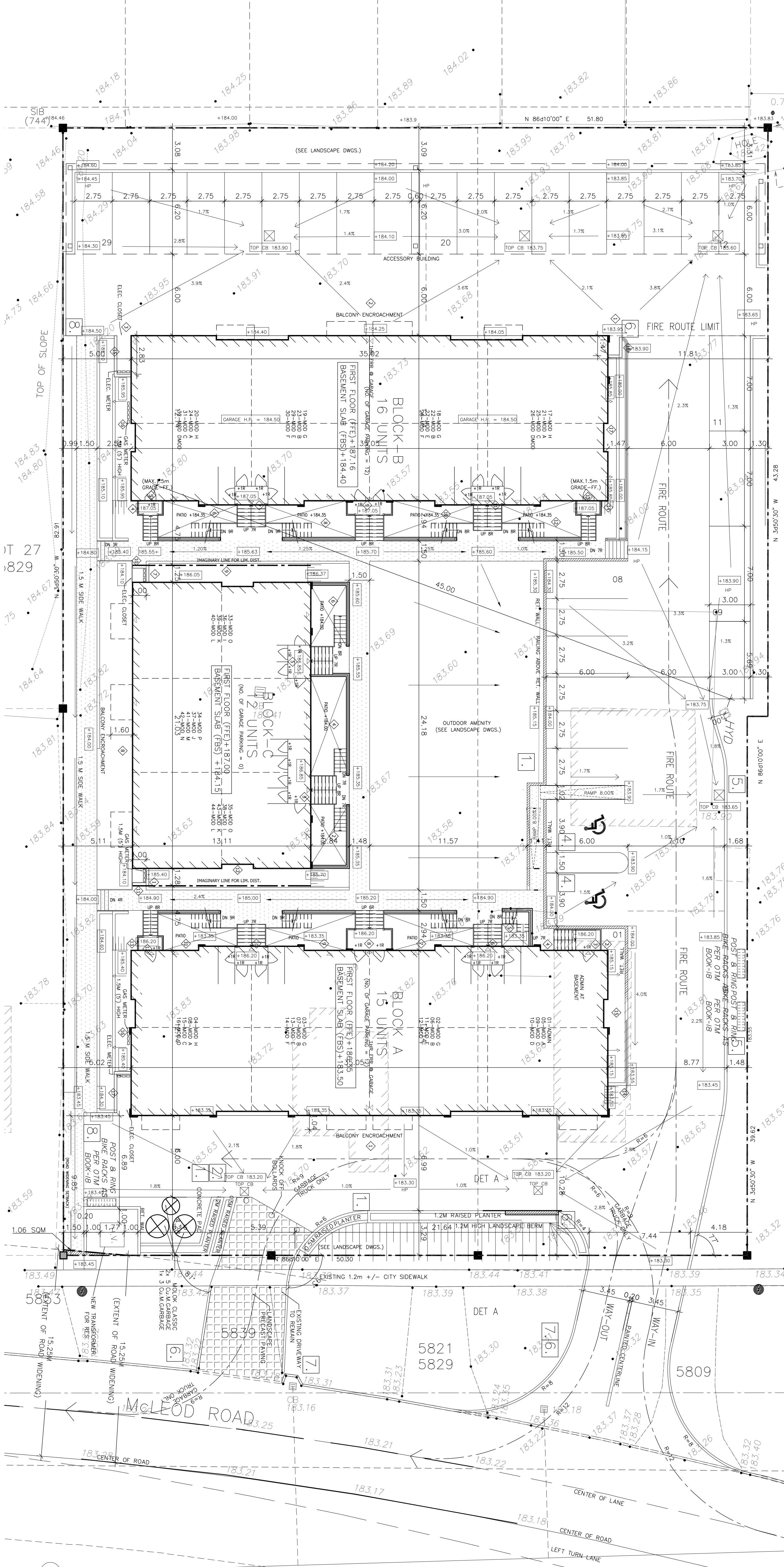

MCLLEOD MANOR STACKED TOWNHOMES

MASTER PLAN

80 CORPORATE DR. SUITE 206, TORONTO, ONTARIO M1H 3J5
 T: 416-467-4657 E: info@vanie.ca Web: www.vanie.ca

VANIE ARCHITECT

Scale: 1:150
 Proj. No: 2021-01
 Drawn by: DL
 Checked by: TFL
 Date 1st Dist: NOV. 03/2022
 Sheet Title: A1.00

CONTRACTOR MUST VERIFY ALL DIMENSIONS ON THE JOB AND REPORT ANY DISCREPANCY TO THE ARCHITECT BEFORE PROCEEDING WITH THE WORK. ALL DRAWINGS AND SPECIFICATIONS ARE INSTRUMENTS OF SERVICE AND THE PROPERTY OF THE ARCHITECT WHICH MUST BE RETURNED AT THE COMPLETION OF THE WORK.