

# LOT 175 PORTAGE ROAD

NIAGARA FALLS, ONTARIO

ISSUED FOR OPA / REZONING

2022-07-06

All drawings, specifications, related documents and design are the copyright property of the architect and must be returned upon request. Reproduction of the drawings, specifications, related documents and design in whole or in part is strictly forbidden without the architect's written permission.

**NOT FOR  
CONSTRUCTION**

**PRELIMINARY**



**CONTACTS**

**CLIENT**

RUDANCO INC.  
4728 DORCHESTER ROAD UNIT 11B 2nd FLOOR  
NIAGARA FALLS, ON, L2E 7H9  
TEL: 905.380.6016

**PROJECT MANAGER**

HORN DESIGN & CONSULTING INC.  
1827 WILL SCARLETT DRIVE  
MISSISSAUGA, ON, L5K 1J6  
TEL: 647.242.6956

**ARCHITECT**

GIANNONE PETRICONE ASSOCIATES INC. ARCHITECTS  
462 WELLINGTON ST. W., SUITE 501  
TORONTO, ON, M5V 1E3  
TEL: 416.591.7788

**PLANNER**

BOUSFIELDS INC.  
3 CHURCH ST., SUITE 200  
TORONTO, ON, M5E 1M2  
TEL: 416.947.9744

**LANDSCAPE ARCHITECT**

JANET ROSENBERG STUDIO  
148 KENWOOD AVE.  
TORONTO, ON, M6C 2S3  
TEL: 416.656.6665

**CIVIL ENGINEER**

MTE 85  
130 BRIDGELAND AVE., SUITE 101  
NORTH YORK, ON, M6A 1Z4  
TEL: 416.489.7888

**TRAFFIC CONSULTANT**

PARADIGM TRANSPORTATION SOLUTIONS LIMITED  
150 PINEBUSH RD., SUITE 5A  
CAMBRIDGE, ON, N1R 8J8  
TEL: 519.896.3163

**WIND & NOISE CONSULTANT**

RWDI  
625 QUEEN ST. W.  
TORONTO, ON, M5V 2B7  
TEL: 647.475.1048

**HERITAGE CONSULTANT**

MHBC  
540 BINGEMANS CENTRE DR., SUITE 200  
KITCHENER, ON, N2B 3X9  
TEL: 519.576.3650

**RAILWAY CONSULTANT**

HATCH  
2800 SPEAKMAN DR.  
MISSISSAUGA, ON L5K 2R7  
TEL: 289.326.1506

**HYDROGEOLOGICAL & GEOTECHNICAL CONSULTANT**

SOIL-MAT  
130 LANCING DR.  
HAMILTON, ON L8W 3A1  
TEL: 905.318.7440

**ACOUSTIC CONSULTANT**

THORNTON TOMASETTI  
116 SPADINA AVE., SUITE 301  
TORONTO, ON, M5V 2K6  
TEL: 416.306.8100

**FORESTRY**

KUNTZ FORESTRY  
PO BOX 1267 LAKESHORE W.  
PO OAKVILLE, ON, L6K 0B3  
TEL: 289.837.1871

**SURVEYOR**

SUDA & MALESZYK SURVEYING INC.  
26 MAIN STREET  
WELLAND, ON, L3B 3W3  
TEL: 905.732.7651

**ENVIRONMENTAL CONSULTANT**

MYLER ECOLOGICAL CONSULTING  
7 OLIVE CR.  
STONE CREEK, ON, L8G 2T2  
TEL: 289.700.3038

**SHEET LIST**

A0.00	COVER PAGE
A0.01	STATISTICS
A0.02	SURVEY
A0.03	CONTEXT PLAN
A0.04	SITE PLAN
A1.01	UNDERGROUND 2 FLOOR PLAN
A1.02	UNDERGROUND 1 FLOOR PLAN
A1.03	GROUND FLOOR PLAN
A1.04	FLOOR 1 MEZZANINE
A1.05	FLOOR 2
A1.06	FLOOR 3
A1.07	FLOOR 4
A1.08	FLOOR 5
A1.09	FLOOR 6
A1.10	TYPICAL TOWER FLOOR PLAN
A2.01	ELEVATION
A2.02	ELEVATION
A2.03	ELEVATIONS
A3.01	SECTION
A3.02	SECTIONS
A4.01	RENDERING
A4.02	RENDERING
A4.03	RENDERING
A4.04	RENDERING
A4.05	RENDERING
A5.01	SHADOW STUDY
A5.02	SHADOW STUDY

1	ISSUED FOR OPA/REZONING	2022-07-06
Revision		Date

**giannone  
petricone  
associates**

Giannone Petricone Associates Inc. Architects  
462 Wellington Street West, Toronto, Canada M5V 1E3,  
T 416.591.7788 F 416.591.1293 E mail@gpaia.com

**RUDANCO INC.**

**PORTAGE RD**

LOT 175 PORTAGE ROAD, CITY OF NIAGARA FALLS,  
ONTARIO

SHEET TITLE

**COVER PAGE**

DRAWN BY:	TW
CHECKED BY:	KL
PROJECT START DATE:	21-10-01
PROJECT NO.:	21140
SHEET NUMBER	

**A0.00**



**NOT FOR CONSTRUCTION**

**PRELIMINARY**

**STATISTICS PER BY-LAW 79-200**

LEVEL	TOTAL LEVELS	FLOOR AREA (M2)							PARKING	BIKE			UNIT MIX						
		AMENITY(M2)			GFA (M2)					RES. VEHICLE PARKING	SHORT TERM BIKE	LONG TERM BIKE	STUDIO	1B	2B	3B	TOTAL		
INDOOR AMENITY	OUTDOOR AMENITY	BALCONY/TERRACE	GFA DEDUCTION /LEVEL	RES. SALEABLE	RES. NON-SALEABLE*	TOTAL GFA	GCA (M2)												
<b>BELOW GRADE</b>																			
UG 1	1	-	-	-	10,630	-	-	10,630	277	-	-	-	-	-	-	-	-		
UG 2	1	-	-	-	10,646	-	-	10,646	286	-	-	-	-	-	-	-	-		
<b>SUB-TOTAL</b>		-	-	-	<b>21,276</b>	-	-	<b>21,276</b>	<b>563</b>	-	-	-	-	-	-	-	-		
<b>PODIUM</b>																			
LEVEL 1	1	1,391	648	-	3,191	-	3,228	3,228	7,810	80	-	-	-	-	-	-	-		
LEVEL 1 MEZZ	1	642	-	-	2,927	-	1,490	1,490	5,059	75	-	-	-	-	-	-	-		
<b>SUB-TOTAL</b>		<b>2,033</b>	<b>648</b>	-	<b>6,118</b>	-	<b>4,718</b>	<b>4,718</b>	<b>12,869</b>	<b>155</b>	-	-	-	-	-	-	-		
<b>TOWER A</b>																			
LEVEL 2	1	-	-	-	2,486	-	1,363	1,363	3,849	61	-	-	-	-	-	-	0		
LEVEL 3	1	541	1,418	141	646	734	1,380	1,380	1,380	-	-	-	5	4	-	-	9		
LEVEL 4	1	-	-	208	961	220	1,181	1,181	-	-	-	-	9	6	-	-	15		
LEVEL 5	1	-	-	181	821	206	1,027	1,027	-	-	-	-	8	5	-	-	13		
LEVEL 6	1	-	-	107	634	110	744	744	-	-	-	-	2	2	-	-	11		
TYP. TOWER				47	643	110	-	-	-	-	-	-	2	6	3	-	11		
LEVEL 7-35	29	-	-	1,363	18,647	3,190	21,837	21,837	-	-	-	-	58	174	87	-	319		
LEVEL MPH	1	-	-	-	-	-	-	-	-	-	-	-	-	-	-	-	0		
<b>SUB-TOTAL</b>		<b>541</b>	<b>1,418</b>	<b>2,000</b>	<b>2,486</b>	<b>21,709</b>	<b>5,823</b>	<b>27,532</b>	<b>30,018</b>	<b>61</b>	-	-	<b>60</b>	<b>203</b>	<b>104</b>	-	<b>367</b>		
<b>TOWER B</b>																			
LEVEL 2	1	472	557	14	192	596	788	788	-	-	-	-	2	1	-	-	3		
LEVEL 3	1	-	-	82	616	110	726	726	-	-	-	-	4	5	2	-	11		
LEVEL 4	1	-	-	47	643	110	753	753	-	-	-	-	2	6	3	-	11		
LEVEL 5	1	-	-	47	643	110	753	753	-	-	-	-	2	6	3	-	11		
LEVEL 6	1	-	-	47	643	110	753	753	-	-	-	-	2	6	3	-	11		
TYP. TOWER				47	643	110	-	-	-	-	-	-	2	6	3	-	11		
LEVEL 7-25	19	-	-	893	12,217	2,090	14,307	14,307	-	-	-	-	38	114	57	-	209		
LEVEL MPH	1	-	-	-	-	-	-	-	-	-	-	-	-	-	-	-	0		
<b>SUB-TOTAL</b>		<b>472</b>	<b>557</b>	<b>1,130</b>	<b>-</b>	<b>14,954</b>	<b>3,126</b>	<b>18,080</b>	<b>18,080</b>	<b>-</b>	-	-	<b>48</b>	<b>139</b>	<b>69</b>	-	<b>256</b>		
<b>TOTALS</b>		<b>3,046</b>	<b>2,623</b>	<b>3,130</b>	<b>29,880</b>	<b>36,663</b>	<b>13,667</b>	<b>50,330</b>	<b>82,243</b>	<b>779</b>	-	-	<b>108</b>	<b>342</b>	<b>173</b>	-	<b>623</b>		
													17%	55%	28%	0%			

\*RESIDENTIAL NON-SALEABLE GFA INCLUDES INDOOR AMENITY AREA

PROJECT SUMMARY		
	AREA (M2)	FSI***
LOT AREA	12,425	
ROAD WIDENING	398	
TOTAL SITE AREA	12,823	
TOTAL GFA	50,330	4.05
DEVELOPMENT DETAILS		
	AREA (M2)	%
BUILDING COVERAGE	7810	63%
LANDSCAPE AREA**	4832	39%
TOTAL BUILDING SIZE	82,243	
BUILDING HEIGHTS		
	STOREYS	HEIGHT (M)*
BUILDING A	35	115.88
BUILDING B	25	83.78

\*BUILDING HEIGHT MEASURED FROM THE ESTABLISHED GRADE  
 \*\*LANDSCAPE AREA EXCLUSIVE OF THE FUTURE ROAD WIDENING  
 \*\*\*FSI IS EXCLUSIVE OF FUTURE ROAD WIDENING

VEHICLE PARKING		
	RATE / UNIT	COUNT
ZONING REQUIRED	1.4	872
PROPOSED PROVIDED*	1.25	779
PARKING TYPES		
BARRIER FREE PARKING	-	17
EVSE	0.2	156

\*REFER TO TRANSPORTATION IMPACT STUDY REPORT

BICYCLE STORAGE		
FLOOR	SHORT TERM	LONG TERM
UNDERGROUND LEVEL 1	-	81
GROUND FLOOR	33	48
SECOND FLOOR	-	202
<b>TOTAL</b>	<b>33</b>	<b>331</b>
RATE (PER UNIT)	0.05	0.53

AMENITY		
	RATE / UNIT	AREA (M2)
INDOOR AMENITY	4.9	3,046
OUTDOOR AMENITY	4.2	2,623
BALCONY/TERRACE	5.0	3,130

**City of Niagara Falls By-law 79-200**

"FLOOR AREA" means, subject to clauses a and b, the aggregate of the horizontal areas of each floor in a building measured to the centre of party walls and to the outside of other walls;

a) in the case of a dwelling or a dwelling unit, the following shall be excluded in calculating the floor area: any private garage, breezeway, unenclosed sunroom, porch, veranda, balcony, basement, cellar and unfinished attic;

b) the floor area of a dwelling unit means the aggregate of the horizontal areas of each floor contained within the dwelling unit measured to the centre of party walls and to the outside of other

1 ISSUED FOR OPA/REZONING 2022-07-06

Revision Date

**giannone  
petricone  
associates**

Giannone Petricone Associates Inc. Architects  
 462 Wellington Street West, Toronto, Canada M5V 1E3,  
 T 416.591.7788 F 416.591.1293 E mail@gpaa.com

RUDANCO INC.

PORTAGE RD

LOT 175 PORTAGE ROAD, CITY OF NIAGARA FALLS,  
 ONTARIO

SHEET TITLE

STATISTICS

DRAWN BY: TW  
 CHECKED BY: KL  
 PROJECT START DATE: 21-10-01  
 PROJECT NO.: 21140  
 SHEET NUMBER

**A0.01**

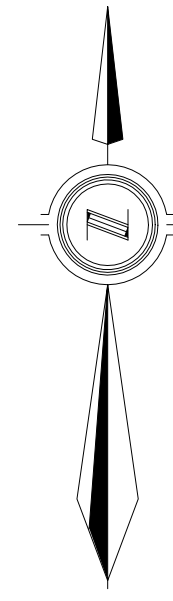

All drawings, specifications, related documents and design are the copyright property of the architect and must be returned upon request. Reproduction of the drawings, specifications, related documents and design in whole or in part is strictly forbidden without the architect's written permission.

**NOT FOR CONSTRUCTION**

**PRELIMINARY**

1 ISSUED FOR OPA/REZONING	2022-07-06
Revision	Date

**giannone  
 petricone  
 associates**  
 Giannone Petricone Associates Inc. Architects  
 462 Wellington Street West, Toronto, Canada M5V 1E3,  
 T 416.591.7788 F 416.591.1293 E mail@gpaia.com

**RUDANCO INC.**

**PORTAGE RD**

LOT 175 PORTAGE ROAD, CITY OF NIAGARA FALLS,  
 ONTARIO

SHEET TITLE

**SURVEY**

DRAWN BY:	Author
CHECKED BY:	Checker
PROJECT START DATE:	21-10-01
PROJECT NO.:	21140
SHEET NUMBER	

**A0.02**



All drawings, specifications, related documents and design are the copyright property of the architect and must be returned upon request. Reproduction of the drawings, specifications, related documents and design in whole or in part is strictly forbidden without the architect's written permission.

**NOT FOR  
CONSTRUCTION**

**PRELIMINARY**



Revision	Date
1 ISSUED FOR OPA/REZONING	2022-07-06

**giannone  
petricone  
associates**

Giannone Petricone Associates Inc. Architects  
462 Wellington Street West, Toronto, Canada M5V 1E3,  
T 416.591.7788 F 416.591.1293 E mail@gpaa.com

**RUDANCO INC.**

**PORTAGE RD**

LOT 175 PORTAGE ROAD, CITY OF NIAGARA FALLS,  
ONTARIO

SHEET TITLE

**CONTEXT PLAN**

DRAWN BY:	TW
CHECKED BY:	KL
PROJECT START DATE:	21-10-01
PROJECT NO.:	21140
SHEET NUMBER	

**A0.03**









1 CONTEXT PLAN  
A0.03 1:5000

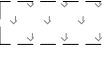

All drawings, specifications, related documents and design are the copyright property of the architect and must be returned upon request. Reproduction of the drawings, specifications, related documents and design in whole or in part is strictly forbidden without the architect's written permission.

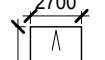
**NOT FOR CONSTRUCTION**

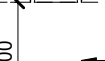
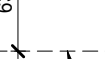
**PRELIMINARY**

-  SECONDARY ACCESS
-  PRIMARY ACCESS
-  RAILWAY SETBACK
-  PROPERTY LINE
-  GREEN ROOF
-  FIRE ROUTE ACCESS
-  TYP. PARKING
-  TYP. DRIVE AISLE
-  TYP. PARKING AS REQUIRED AS PER ZONING-BY-LAW 79-200-4-19 TABLE 2
-  ACCESSIBLE PARKING

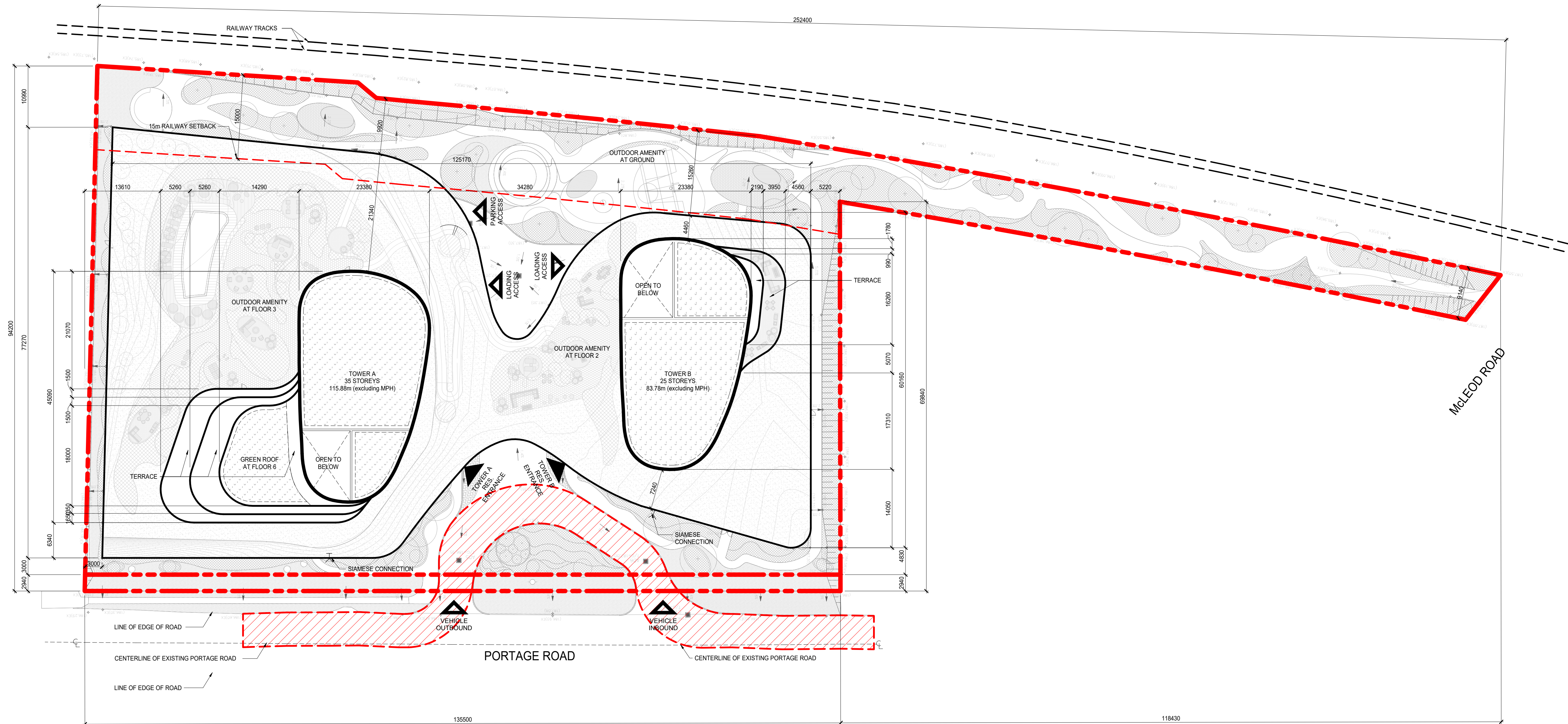

1 SITE PLAN  
A0.04 1:400

Revision	Date
1 ISSUED FOR OPA/REZONING	2022-07-06

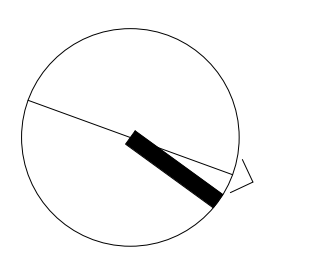

**giannone  
petricone  
associates**

Giannone Petricone Associates Inc. Architects  
462 Wellington Street West, Toronto, Canada M5V 1E3,  
T 416.591.7788 F 416.591.1293 E mail@gpaia.com

**RUDANCO INC.**

**PORTAGE RD**

LOT 175 PORTAGE ROAD, CITY OF NIAGARA FALLS,  
ONTARIO

SHEET TITLE

**SITE PLAN**

DRAWN BY:	TW
CHECKED BY:	KL
PROJECT START DATE:	21-10-01
PROJECT NO.:	21140
SHEET NUMBER	

**A0.04**



All drawings, specifications, related documents and design are the copyright property of the architect and must be returned upon request. Reproduction of the drawings, specifications, related documents and design in whole or in part is strictly forbidden without the architect's written permission.

**NOT FOR CONSTRUCTION**  
**PRELIMINARY**

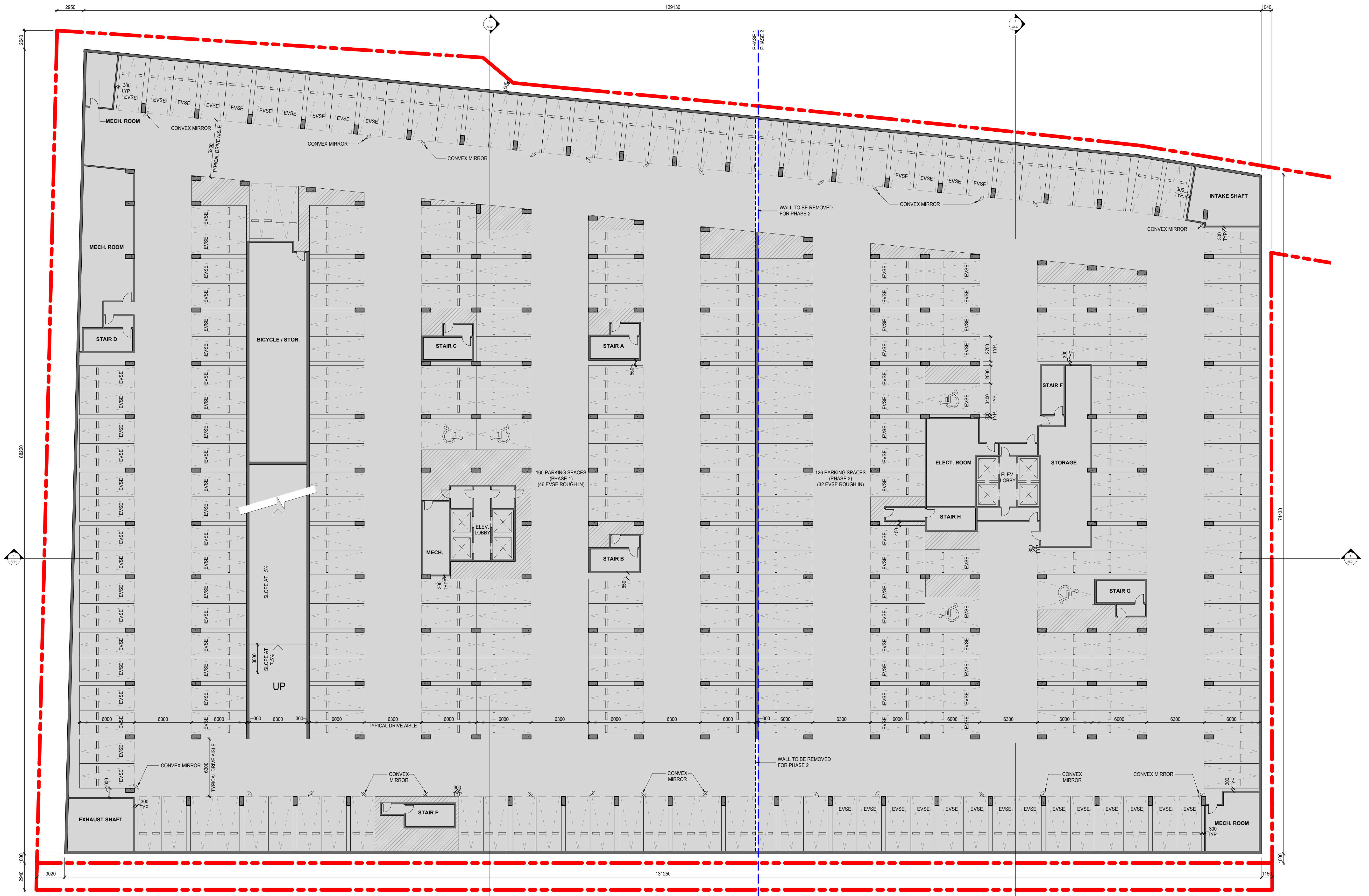
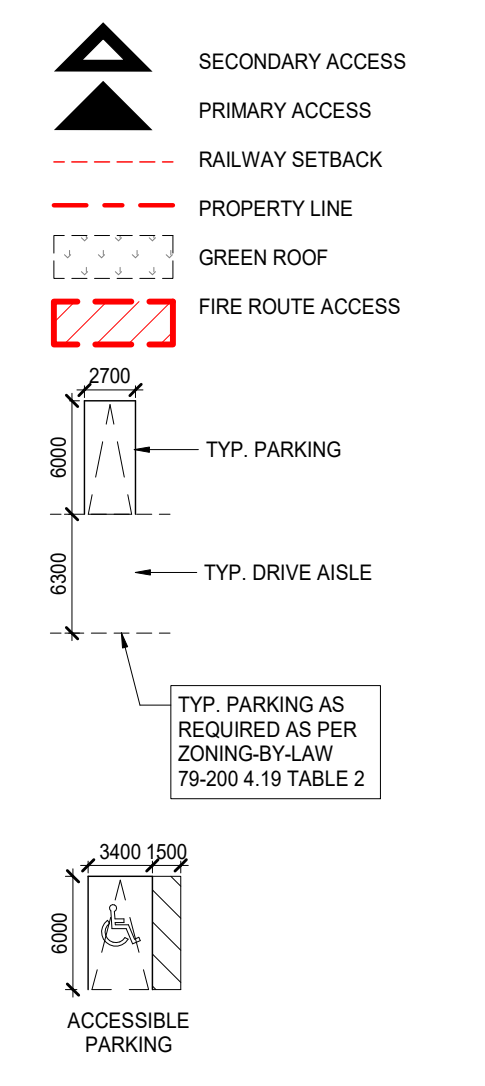

1 ISSUED FOR OPA/REZONING 2022-07-06

Revision Date

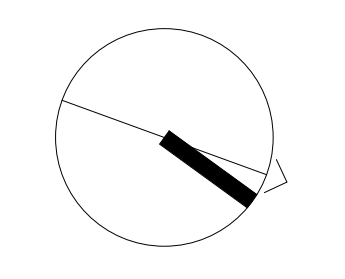

**giannone  
petricone  
associates**

Giannone Petricone Associates Inc. Architects  
462 Wellington Street West, Toronto, Canada M5V 1E3,  
T 416.591.7788 F 416.591.1293 E mail@gpaia.com

**RUDANCO INC.**

**PORTAGE RD**

LOT 175 PORTAGE ROAD, CITY OF NIAGARA FALLS,  
ONTARIO

SHEET TITLE

**UNDERGROUND 2 FLOOR  
PLAN**

DRAWN BY: TW  
CHECKED BY: KL  
PROJECT START DATE: 21-10-01  
PROJECT NO.: 21140  
SHEET NUMBER

**A1.01**

1 UNDERGROUND 2 FLOOR PLAN  
A1.01 1: 200



All drawings, specifications, related documents and design are the copyright property of the architect and must be returned upon request. Reproduction of the drawings, specifications, related documents and design in whole or in part is strictly forbidden without the architect's written permission.

**NOT FOR CONSTRUCTION**  
**PRELIMINARY**

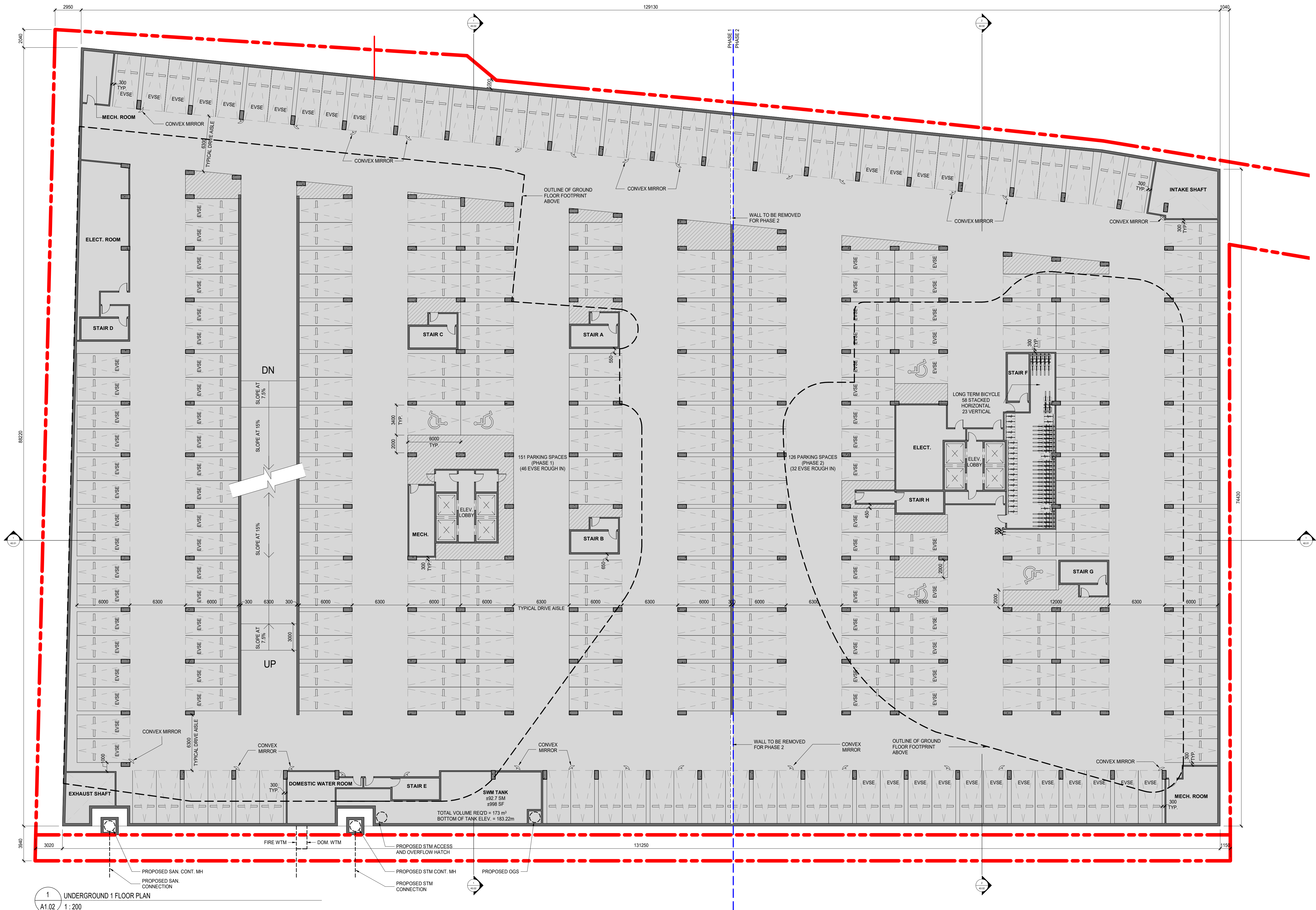
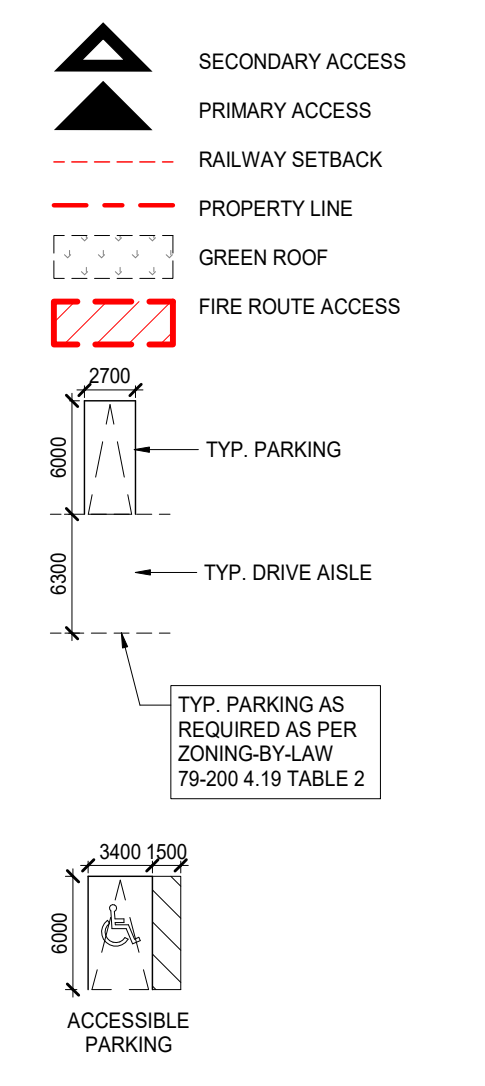

1 UNDERGROUND 1 FLOOR PLAN  
A1.02 1:200

1 ISSUED FOR OPA/REZONING 2022-07-06

Revision Date

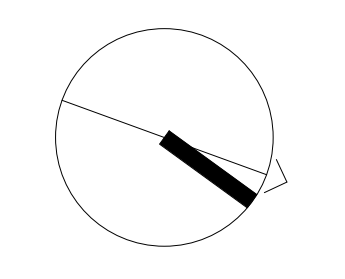

**giannone  
petricone  
associates**

Giannone Petricone Associates Inc. Architects  
462 Wellington Street West, Toronto, Canada M5V 1E3,  
T 416.591.7788 F 416.591.1293 E mail@gpaia.com

**RUDANCO INC.**

**PORTAGE RD**

LOT 175 PORTAGE ROAD, CITY OF NIAGARA FALLS,  
ONTARIO

SHEET TITLE

**UNDERGROUND 1 FLOOR  
PLAN**

DRAWN BY: TW  
CHECKED BY: KL  
PROJECT START DATE: 21-10-01  
PROJECT NO.: 21140  
SHEET NUMBER

**A1.02**



All drawings, specifications, related documents and design are the copyright property of the architect and must be returned upon request. Reproduction of the drawings, specifications, related documents and design in whole or in part is strictly forbidden without the architect's written permission.

**NOT FOR CONSTRUCTION**  
**PRELIMINARY**

- SECONDARY ACCESS
- PRIMARY ACCESS
- RAILWAY SETBACK
- PROPERTY LINE
- GREEN ROOF
- FIRE ROUTE ACCESS
- TYP. PARKING
- TYP. DRIVE AISLE
- TYP. PARKING AS REQUIRED AS PER ZONING-BY-LAW 79-2004.19 TABLE 2
- ACCESSIBLE PARKING

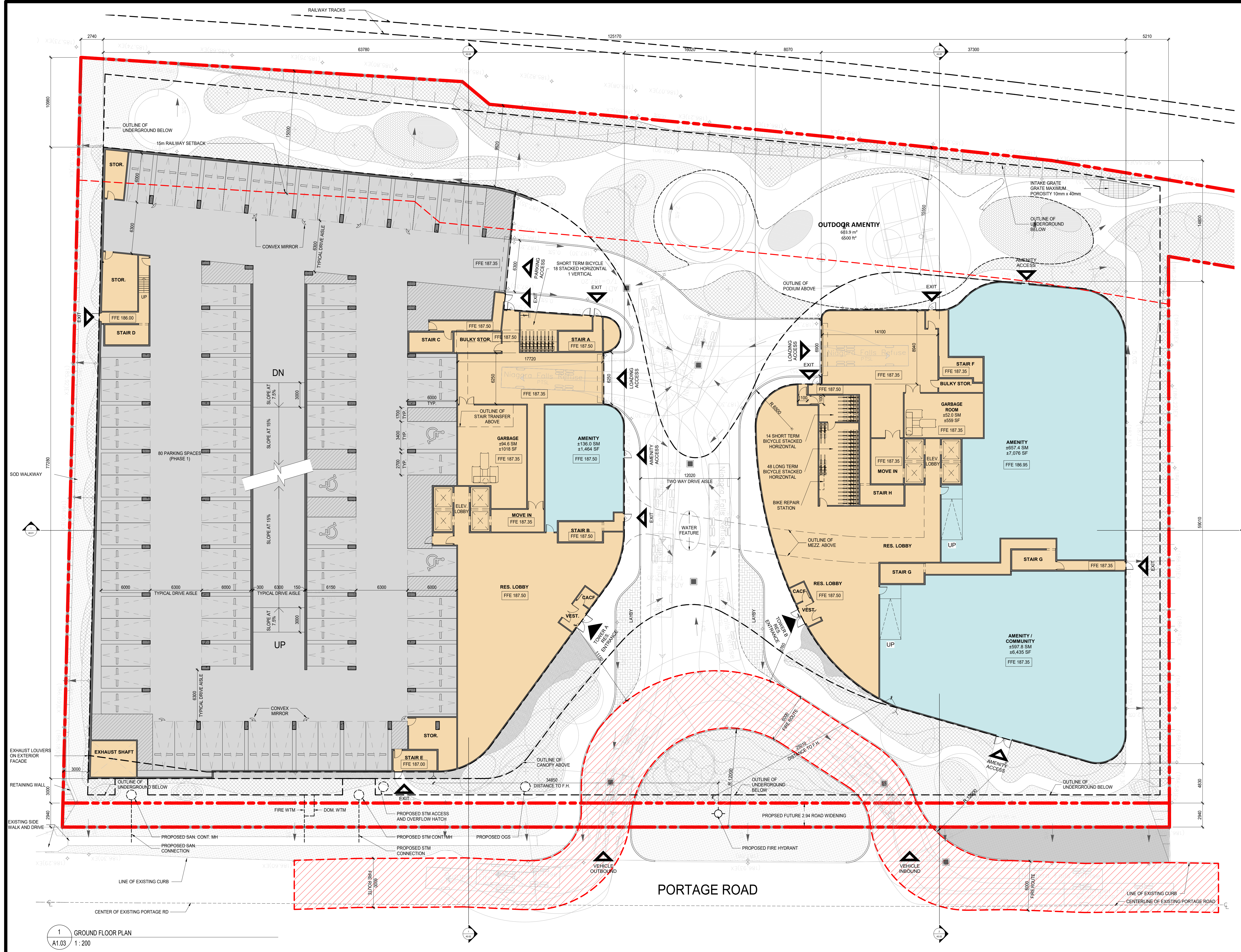

1 ISSUED FOR OPA/REZONING 2022-07-06

Revision Date

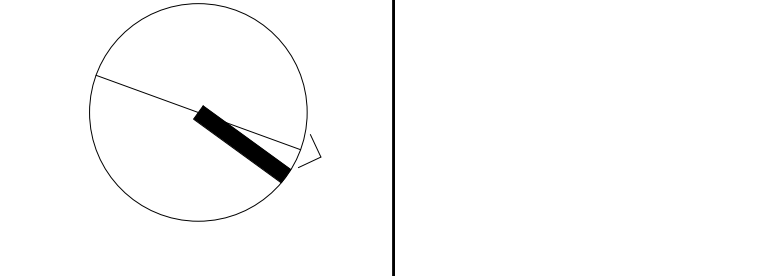

**giannone  
petricone  
associates**

Giannone Petricone Associates Inc. Architects  
462 Wellington Street West, Toronto, Canada M5V 1E3,  
T 416.591.7788 F 416.591.1293 E mail@gpaia.com

**RUDANCO INC.**

**PORTAGE RD**

LOT 175 PORTAGE ROAD, CITY OF NIAGARA FALLS,  
ONTARIO

SHEET TITLE

**GROUND FLOOR PLAN**

DRAWN BY: TW  
CHECKED BY: KL  
PROJECT START DATE: 21-10-01  
PROJECT NO.: 21140  
SHEET NUMBER

**A1.03**









1 GROUND FLOOR PLAN  
A1.03  
1:200

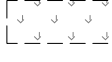

All drawings, specifications, related documents and design are the copyright property of the architect and must be returned upon request. Reproduction of the drawings, specifications, related documents and design in whole or in part is strictly forbidden without the architect's written permission.

**NOT FOR CONSTRUCTION**

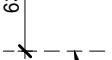
**PRELIMINARY**

-  SECONDARY ACCESS
-  PRIMARY ACCESS
-  RAILWAY SETBACK
-  PROPERTY LINE
-  GREEN ROOF
-  FIRE ROUTE ACCESS
-  TYP. PARKING
-  TYP. DRIVE AISLE
-  TYP. PARKING AS REQUIRED BY LAW PER ZONING BY-LAW 79-2004.19 TABLE 2
-  ACCESSIBLE PARKING

1 ISSUED FOR OPA/REZONING 2022-07-06

Revision Date

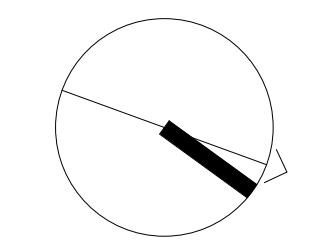

**giannone  
petricono  
associates**

Giannone Petricono Associates Inc. Architects  
462 Wellington Street West, Toronto, Canada M5V 1E3,  
T 416.591.7788 F 416.591.1293 E mail@gpaa.com

**RUDANCO INC.**

**PORTAGE RD**

LOT 175 PORTAGE ROAD, CITY OF NIAGARA FALLS,  
ONTARIO

SHEET TITLE

**FLOOR 1 MEZZANINE**

DRAWN BY: TW  
CHECKED BY: KL  
PROJECT START DATE: 21-10-01  
PROJECT NO.: 21140  
SHEET NUMBER

**A1.04**

PLOT DATE: 2022-08-03 11:54:10 AM

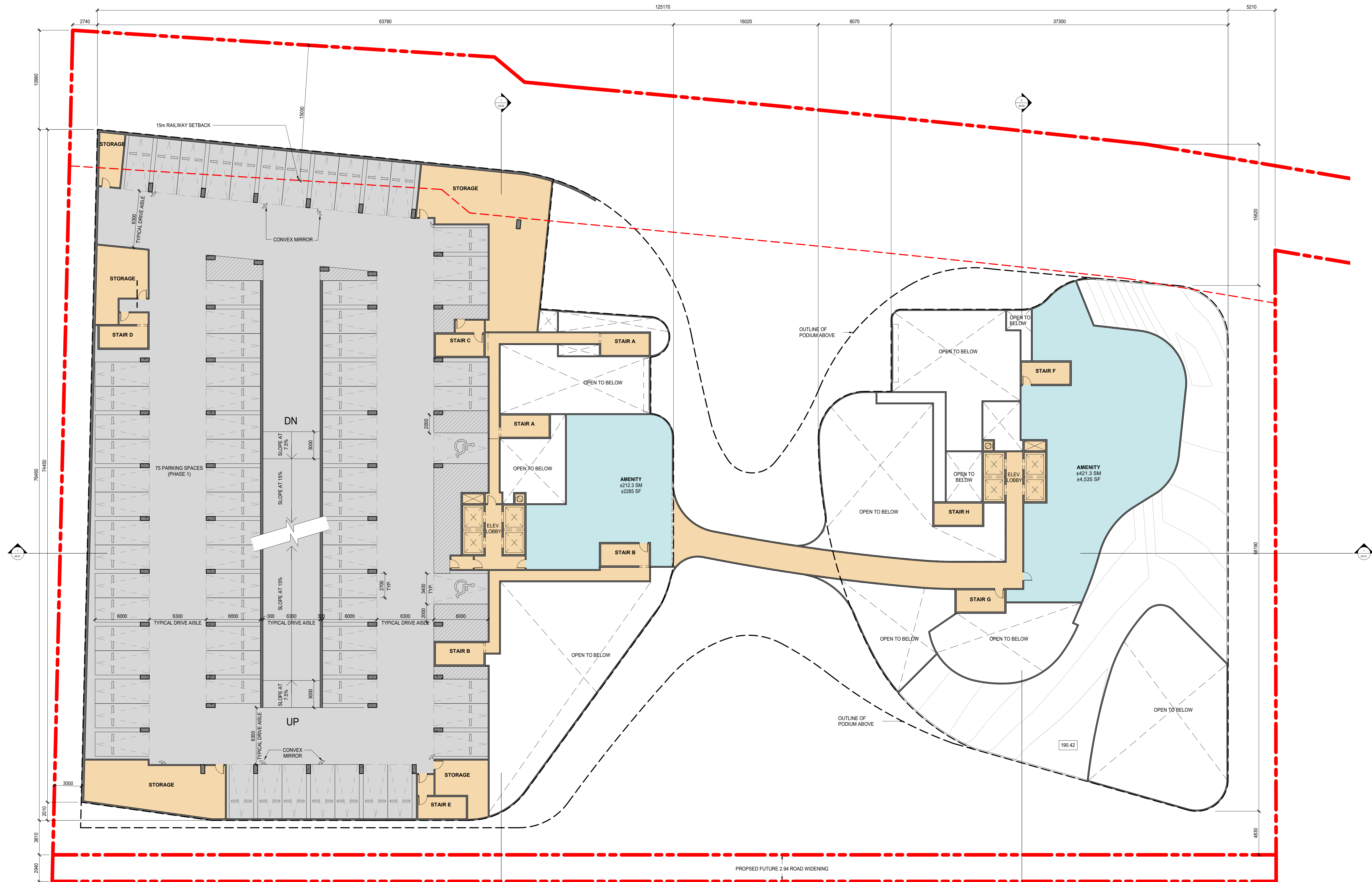









1 FLOOR 1 MEZZANINE  
A1.04 1:200

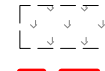

All drawings, specifications, related documents and design are the copyright property of the architect and must be returned upon request. Reproduction of the drawings, specifications, related documents and design in whole or in part is strictly forbidden without the architect's written permission.

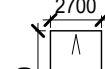
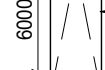
**NOT FOR CONSTRUCTION**

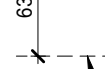
**PRELIMINARY**

-  SECONDARY ACCESS
-  PRIMARY ACCESS
-  RAILWAY SETBACK
-  PROPERTY LINE
-  GREEN ROOF
-  FIRE ROUTE ACCESS
-  TYP. PARKING
-  TYP. DRIVE AISLE
-  TYP. PARKING AS PER ZONING-BY-LAW 78-200-4.19 TABLE 2
-  ACCESSIBLE PARKING

1 ISSUED FOR OPA/REZONING 2022-07-06

Revision Date

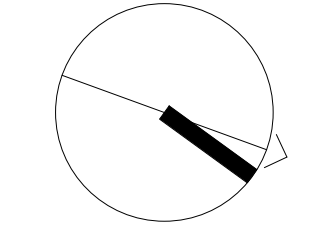

**giannone  
petricone  
associates**

Giannone Petricone Associates Inc. Architects  
462 Wellington Street West, Toronto, Canada M5V 1E3,  
T 416.591.7788 F 416.591.1293 E mail@gpaa.com

**RUDANCO INC.**

**PORTAGE RD**

LOT 175 PORTAGE ROAD, CITY OF NIAGARA FALLS,  
ONTARIO

SHEET TITLE

**FLOOR 2**

DRAWN BY: TW  
CHECKED BY: KL  
PROJECT START DATE: 21-10-01  
PROJECT NO.: 21140  
SHEET NUMBER

**A1.05**

PLOT DATE: 2022-08-03 12:11:14 PM

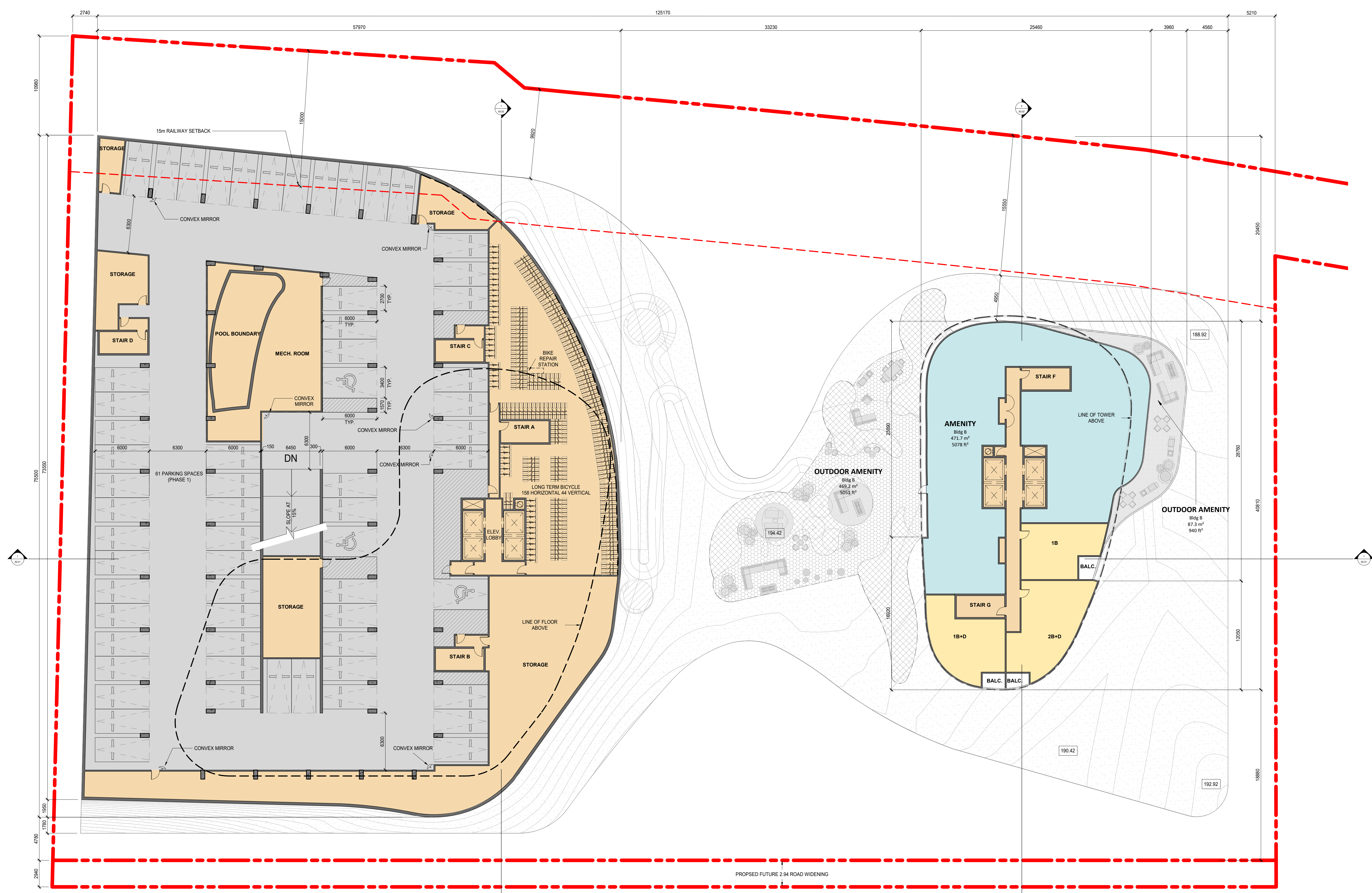









1 FLOOR 2  
A1.05 1: 200

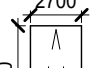

All drawings, specifications, related documents and design are the copyright property of the architect and must be returned upon request. Reproduction of the drawings, specifications, related documents and design in whole or in part is strictly forbidden without the architect's written permission.

**NOT FOR CONSTRUCTION**

**PRELIMINARY**

-  SECONDARY ACCESS
-  PRIMARY ACCESS
-  RAILWAY SETBACK
-  PROPERTY LINE
-  GREEN ROOF
-  FIRE ROUTE ACCESS
-  TYP. PARKING
-  TYP. DRIVE AISLE
-  TYP. PARKING AS REQUIRED AS PER ZONING-BY-LAW 78-2004.19 TABLE 2
-  ACCESSIBLE PARKING

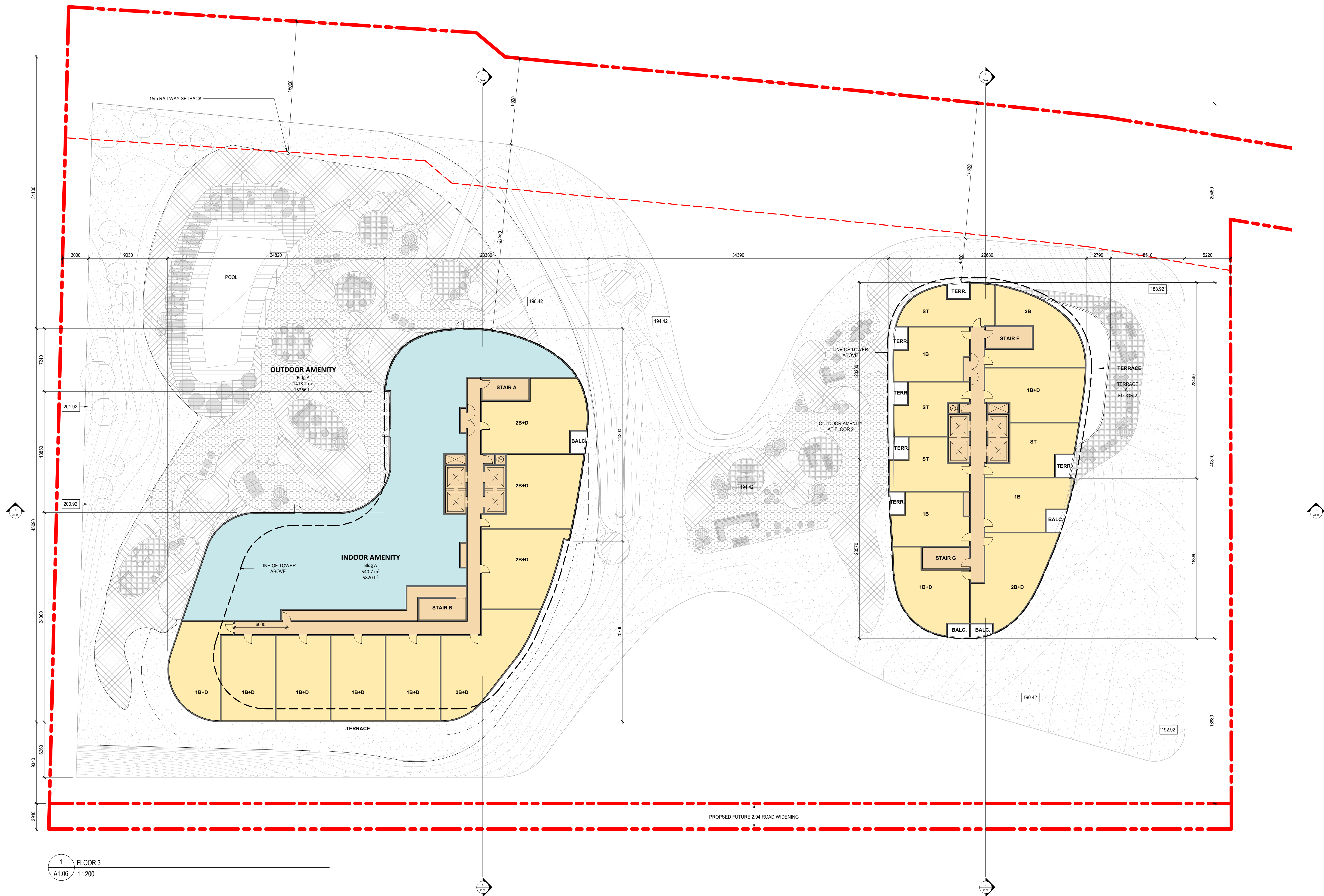

1 FLOOR 3  
A1.06 1:200

1 ISSUED FOR OPA/REZONING 2022-07-06  
Revision Date

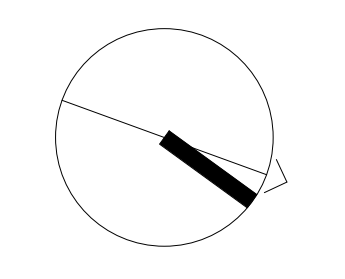

**giannone  
petricone  
associates**

Giannone Petricone Associates Inc. Architects  
462 Wellington Street West, Toronto, Canada M5V 1E3,  
T 416.591.7788 F 416.591.1293 E mail@gpaia.com

**RUDANCO INC.**

**PORTAGE RD**

LOT 175 PORTAGE ROAD, CITY OF NIAGARA FALLS,  
ONTARIO

SHEET TITLE

**FLOOR 3**

DRAWN BY: TW  
CHECKED BY: KL  
PROJECT START DATE: 21-10-01  
PROJECT NO.: 21140  
SHEET NUMBER









**A1.06**

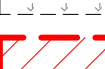

All drawings, specifications, related documents and design are the copyright property of the architect and must be returned upon request. Reproduction of the drawings, specifications, related documents and design in whole or in part is strictly forbidden without the architect's written permission.

**NOT FOR CONSTRUCTION**

**PRELIMINARY**

-  SECONDARY ACCESS
-  PRIMARY ACCESS
-  RAILWAY SETBACK
-  PROPERTY LINE
-  GREEN ROOF
-  FIRE ROUTE ACCESS
-  TYP. PARKING
-  TYP. DRIVE AISLE
-  TYP. PARKING AS REQUIRED AS PER ZONING BY-LAW 79-2004.19 TABLE 2
-  ACCESSIBLE PARKING

Revision	Date
1 ISSUED FOR OPA/REZONING	2022-07-06

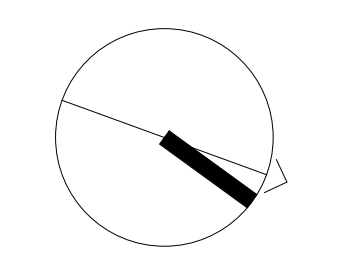

**giannone  
petricone  
associates**

Giannone Petricone Associates Inc. Architects  
462 Wellington Street West, Toronto, Canada M5V 1E3,  
T 416.591.7788 F 416.591.1293 E mail@goaia.com

**RUDANCO INC.**

**PORTAGE RD**

LOT 175 PORTAGE ROAD, CITY OF NIAGARA FALLS,  
ONTARIO

SHEET TITLE

**FLOOR 4**

DRAWN BY:	TW
CHECKED BY:	KL
PROJECT START DATE:	21-10-01
PROJECT NO.:	21140
SHEET NUMBER	

**A1.07**

PLOT DATE: 2022-07-26 8:40:36 PM

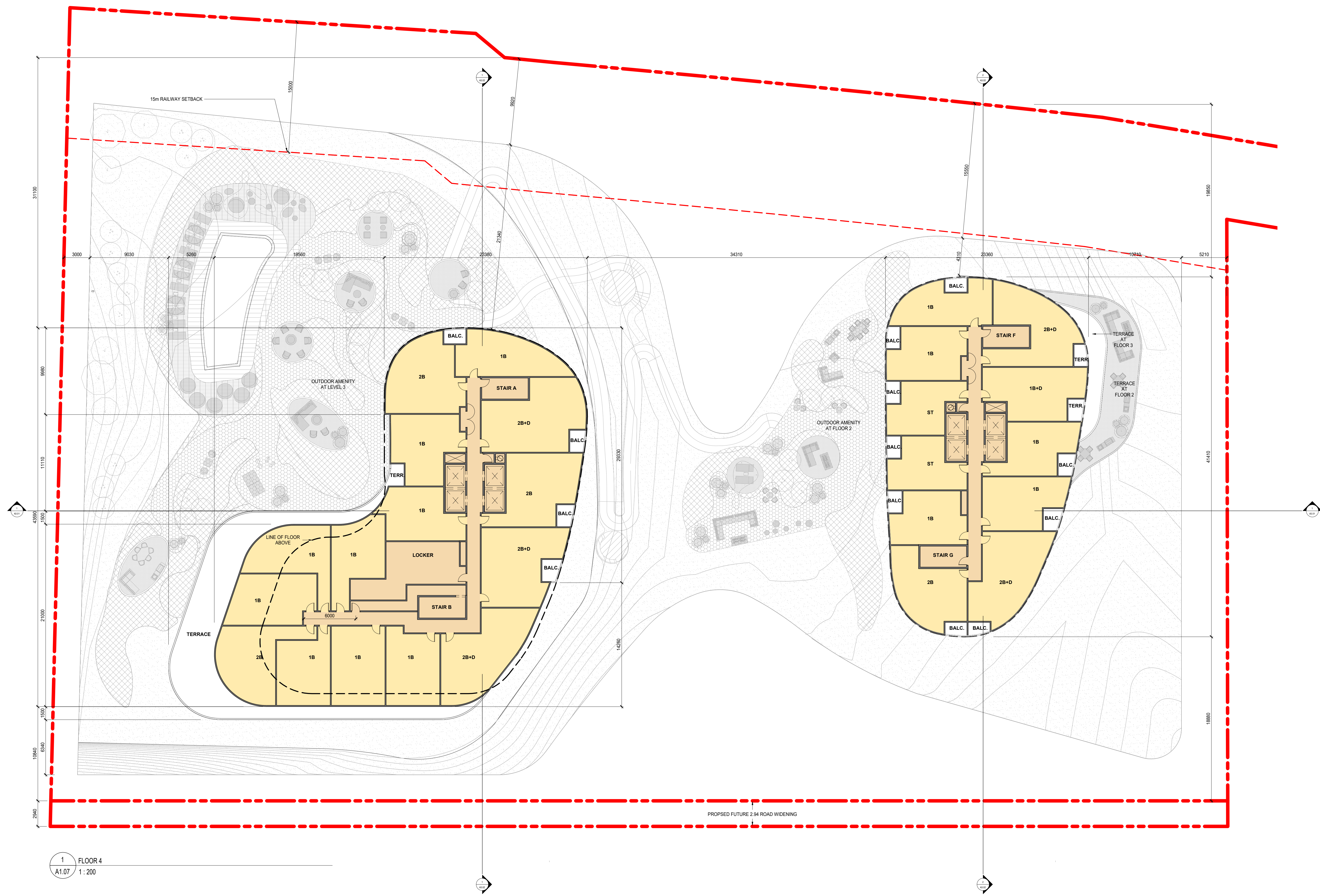









1 FLOOR 4  
A1.07 1:200

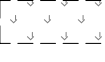

All drawings, specifications, related documents and design are the copyright property of the architect and must be returned upon request. Reproduction of the drawings, specifications, related documents and design in whole or in part is strictly forbidden without the architect's written permission.

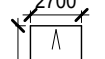
**NOT FOR CONSTRUCTION**

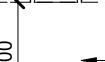
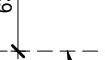
**PRELIMINARY**

-  SECONDARY ACCESS
-  PRIMARY ACCESS
-  RAILWAY SETBACK
-  PROPERTY LINE
-  GREEN ROOF
-  FIRE ROUTE ACCESS
-  TYP. PARKING
-  TYP. DRIVE AISLE
-  TYP. PARKING AS REQUIRED AS PER ZONING BY-LAW 79-2004.19 TABLE 2
-  ACCESSIBLE PARKING

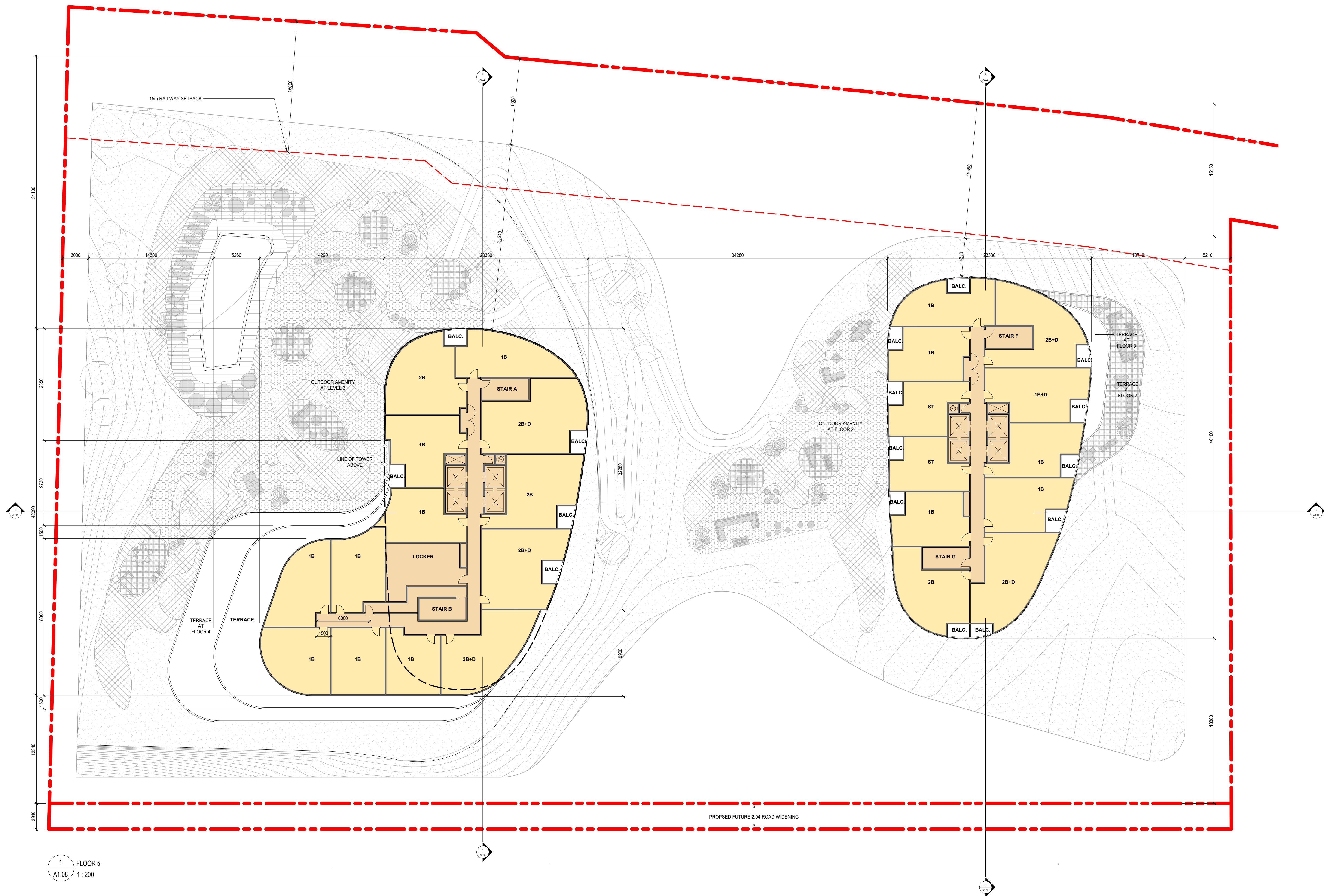

1 FLOOR 5  
A1.08 1:200

1 ISSUED FOR OPA/REZONING 2022-07-06  
Revision Date

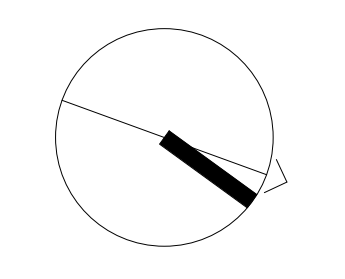

**giannone  
petricone  
associates**

Giannone Petricone Associates Inc. Architects  
462 Wellington Street West, Toronto, Canada M5V 1E3,  
T 416.591.7788 F 416.591.1293 E mail@gpaia.com

RUDANCO INC.

PORTAGE RD

LOT 175 PORTAGE ROAD, CITY OF NIAGARA FALLS,  
ONTARIO

SHEET TITLE

FLOOR 5

DRAWN BY: TW  
CHECKED BY: KL  
PROJECT START DATE: 21-10-01  
PROJECT NO.: 21140  
SHEET NUMBER









**A1.08**

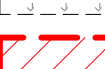

All drawings, specifications, related documents and design are the copyright property of the architect and must be returned upon request. Reproduction of the drawings, specifications, related documents and design in whole or in part is strictly forbidden without the architect's written permission.

**NOT FOR CONSTRUCTION**

**PRELIMINARY**

-  SECONDARY ACCESS
-  PRIMARY ACCESS
-  RAILWAY SETBACK
-  PROPERTY LINE
-  GREEN ROOF
-  FIRE ROUTE ACCESS
-  TYP. PARKING
-  TYP. DRIVE AISLE
-  TYP. PARKING AS REQUIRED AS PER ZONING-BY-LAW 79-200-4-19 TABLE 2
-  ACCESSIBLE PARKING

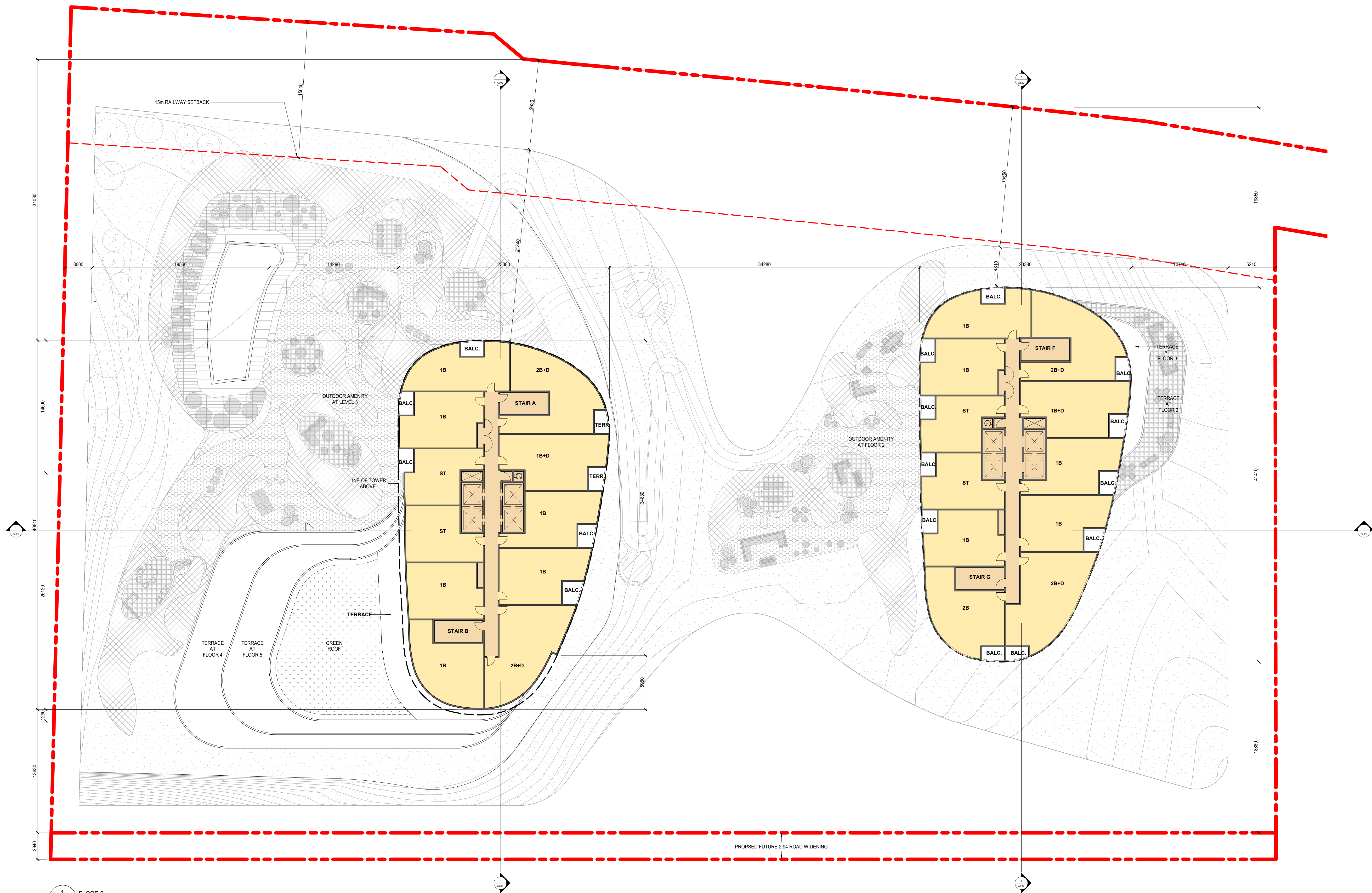

1 FLOOR 6  
A1.09 1:200

1 ISSUED FOR OPA/REZONING	2022-07-06
Revision	Date

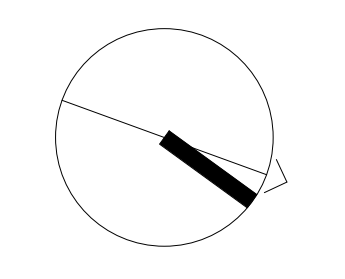

**giannone  
petricone  
associates**

Giannone Petricone Associates Inc. Architects  
462 Wellington Street West, Toronto, Canada M5V 1E3,  
T 416.591.7788 F 416.591.1293 E mail@gpaa.com

**RUDANCO INC.**

**PORTAGE RD**

LOT 175 PORTAGE ROAD, CITY OF NIAGARA FALLS,  
ONTARIO

SHEET TITLE

**FLOOR 6**

DRAWN BY:	TW
CHECKED BY:	KL
PROJECT START DATE:	21-10-01
PROJECT NO.:	21140
SHEET NUMBER	

**A1.09**



All drawings, specifications, related documents and design are the copyright property of the architect and must be returned upon request. Reproduction of the drawings, specifications, related documents and design in whole or in part is strictly forbidden without the architect's written permission.

**NOT FOR CONSTRUCTION**

**PRELIMINARY**

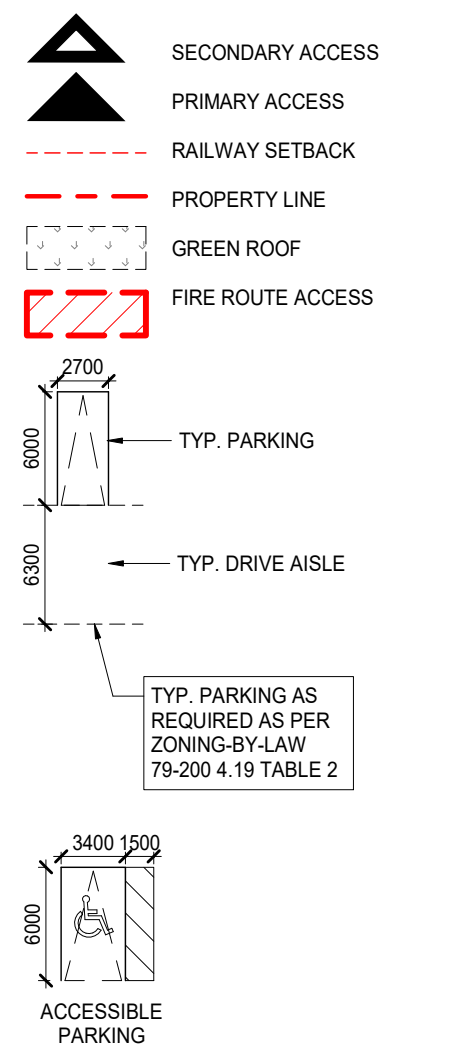

**29 STORY TOWER**  
# UNIT: 324

**25 STORY TOWER**  
# UNIT: 276

1 ISSUED FOR OPA/REZONING 2022-07-06  
Revision Date

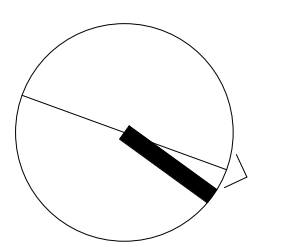

**giannone  
petricone  
associates**

Giannone Petricone Associates Inc. Architects  
462 Wellington Street West, Toronto, Canada M5V 1E3,  
T 416.591.7788 F 416.591.1293 E mail@gpaa.com

**RUDANCO INC.**

**PORTAGE RD**

LOT 175 PORTAGE ROAD, CITY OF NIAGARA FALLS,  
ONTARIO

SHEET TITLE

TYPICAL TOWER FLOOR PLAN

DRAWN BY: TW  
CHECKED BY: KL  
PROJECT START DATE: 21-10-01  
PROJECT NO.: 21140  
SHEET NUMBER

**A1.10**

PLOT DATE: 2022-07-26 8:42:09 PM

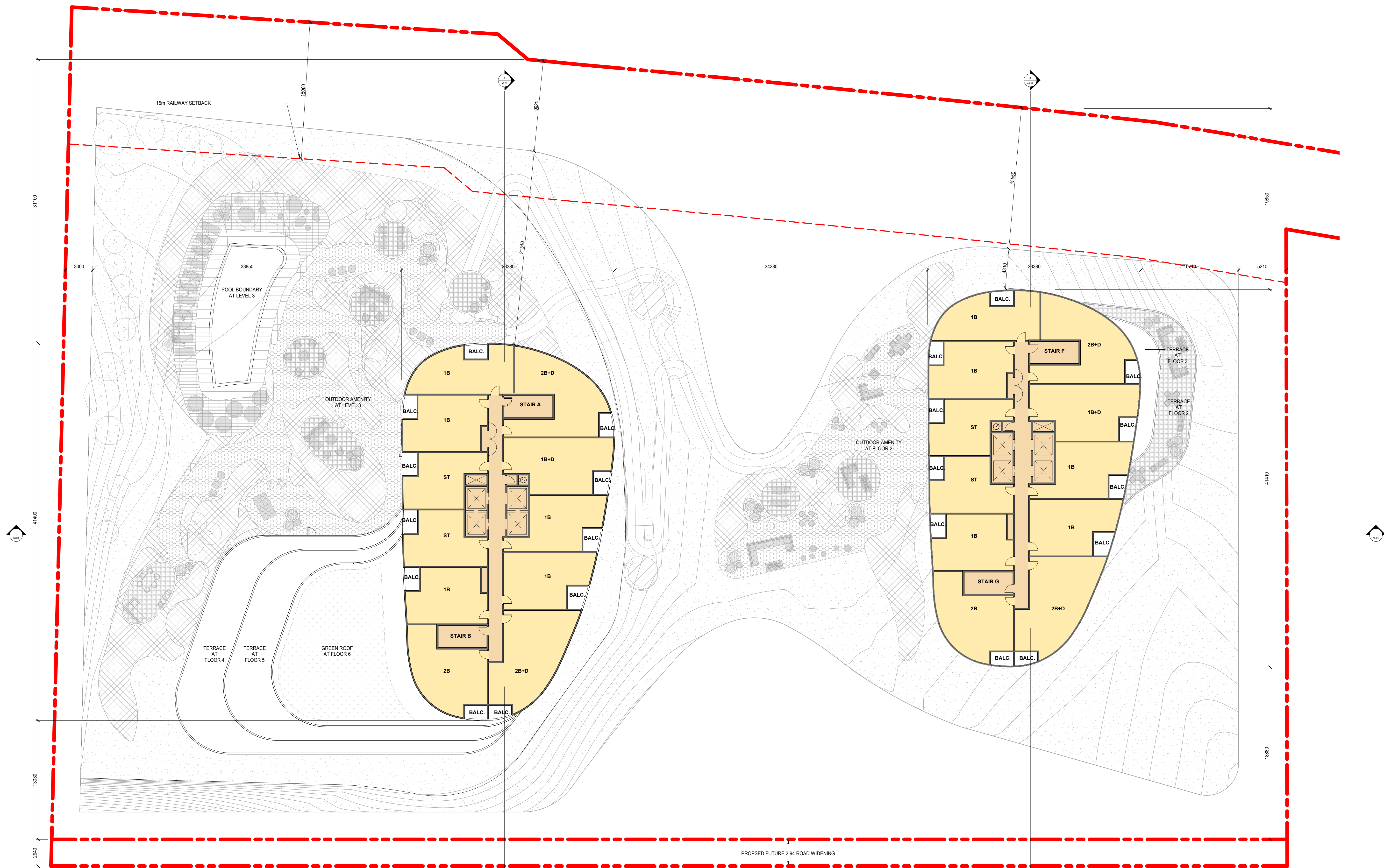

1 TYPICAL TOWER FLOOR PLAN  
A1.10 1:200



All drawings, specifications, related documents and design are the copyright property of the architect and must be returned upon request. Reproduction of the drawings, specifications, related documents and design in whole or in part is strictly forbidden without the architect's written permission.

**NOT FOR  
CONSTRUCTION**

**PRELIMINARY**

**MATERIAL LEGEND**

- GL1 VISION GLAZING
- GL2 VISION GLAZING
- GR1 GLAZING RAILING
- SP1 SPANDREL GLAZING
- MP1 METAL PANEL
- MP2 METAL MULLION

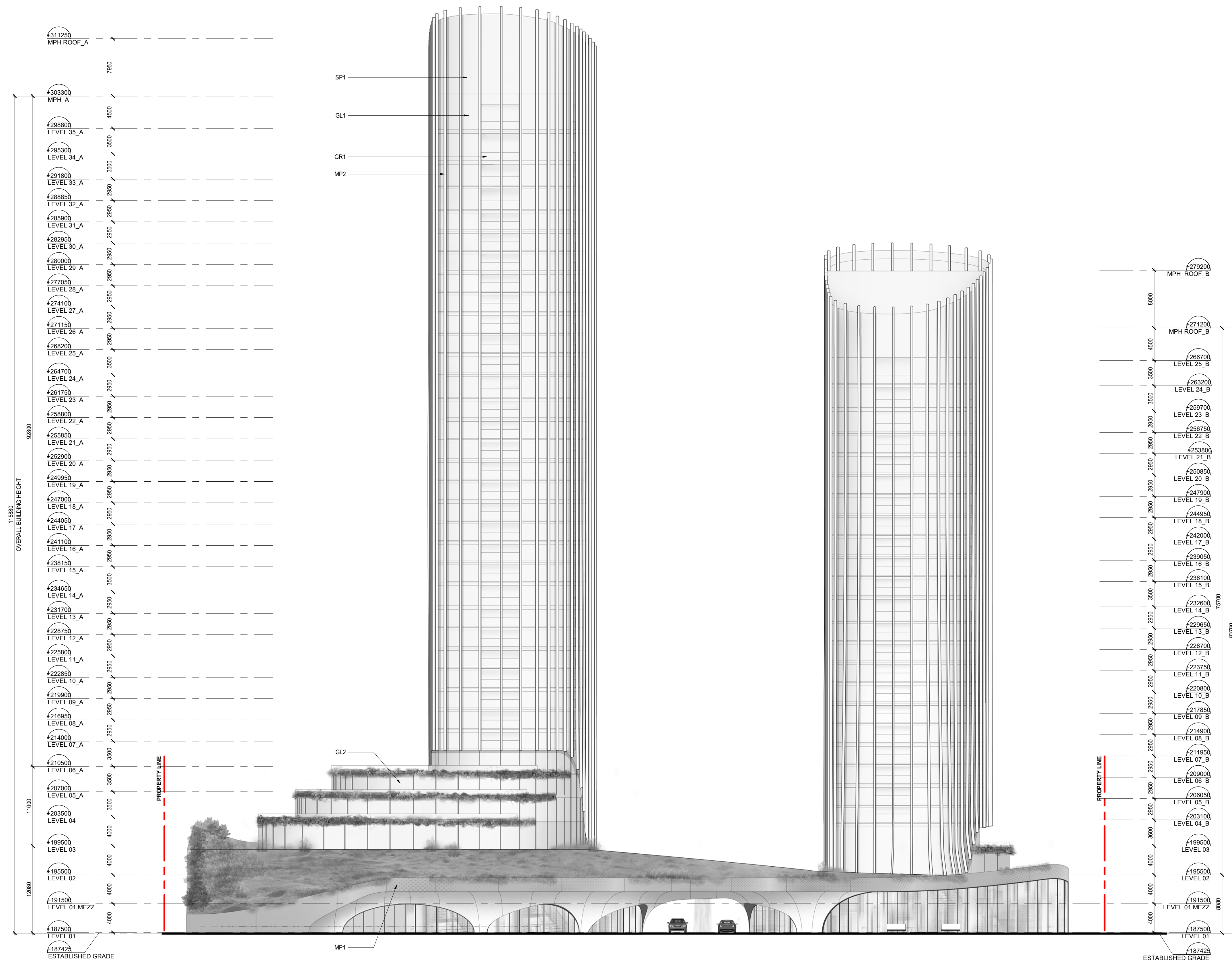

1 EAST ELEVATION  
A2.01 1:300

Revision	Date
1 ISSUED FOR OPA/REZONING	2022-07-06

**giannone  
petricone  
associates**

Giannone Petricone Associates Inc. Architects  
462 Wellington Street West, Toronto, Canada M5V 1E3,  
T 416.591.7788 F 416.591.1293 E mail@gpaa.com

**RUDANCO INC.**

**PORTAGE RD**

LOT 175 PORTAGE ROAD, CITY OF NIAGARA FALLS,  
ONTARIO

SHEET TITLE

**ELEVATION**

DRAWN BY:	TW
CHECKED BY:	KL
PROJECT START DATE:	21-10-01
PROJECT NO.:	21140
SHEET NUMBER	

**A2.01**



All drawings, specifications, related documents and design are the copyright property of the architect and must be returned upon request. Reproduction of the drawings, specifications, related documents and design in whole or in part is strictly forbidden without the architect's written permission.

**NOT FOR CONSTRUCTION**

**PRELIMINARY**

**MATERIAL LEGEND**

- GL1 VISION GLAZING
- GL2 VISION GLAZING
- GR1 GLAZING RAILING
- SP1 SPANDREL GLAZING
- MP1 METAL PANEL
- MP2 METAL MULLION

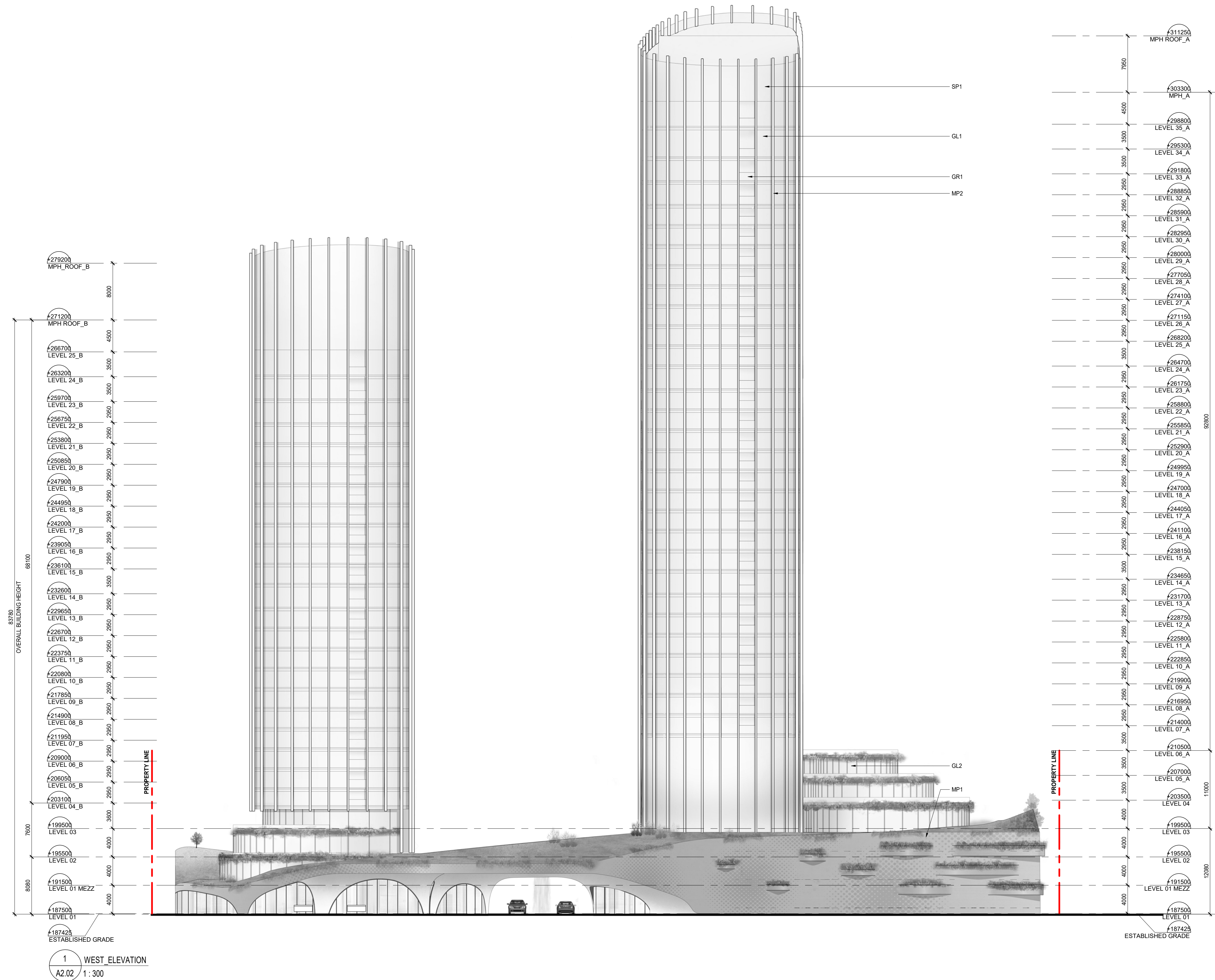

1 ISSUED FOR OPA/REZONING 2022-07-06

Revision Date

**giannone  
petricone  
associates**

Giannone Petricone Associates Inc. Architects  
462 Wellington Street West, Toronto, Canada M5V 1E3,  
T 416.591.7788 F 416.591.1293 E mail@gpaia.com

**RUDANCO INC.**

**PORTAGE RD**

LOT 175 PORTAGE ROAD, CITY OF NIAGARA FALLS,  
ONTARIO

SHEET TITLE

**ELEVATION**

DRAWN BY: TW  
CHECKED BY: KL  
PROJECT START DATE: 21-10-01  
PROJECT NO.: 21140  
SHEET NUMBER

**A2.02**



All drawings, specifications, related documents and design are the copyright property of the architect and must be returned upon request. Reproduction of the drawings, specifications, related documents and design in whole or in part is strictly forbidden without the architect's written permission.

**NOT FOR  
CONSTRUCTION**

**PRELIMINARY**

**MATERIAL LEGEND**

- GL1 VISION GLAZING
- GL2 VISION GLAZING
- GR1 GLAZING RAILING
- SP1 SPANDREL GLAZING
- MP1 METAL PANEL
- MP2 METAL MULLION

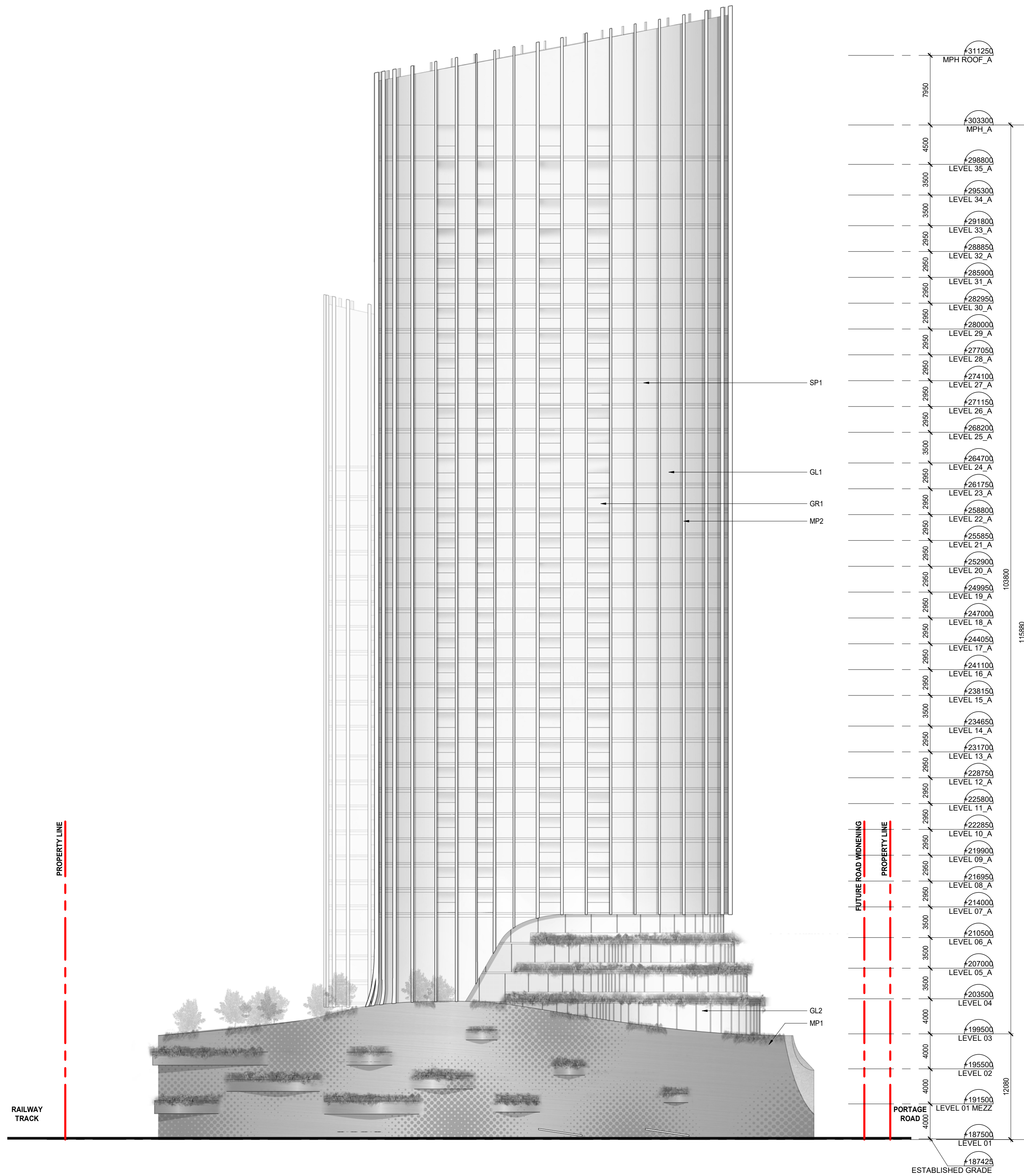

1 NORTH ELEVATION  
A2.03 1:300

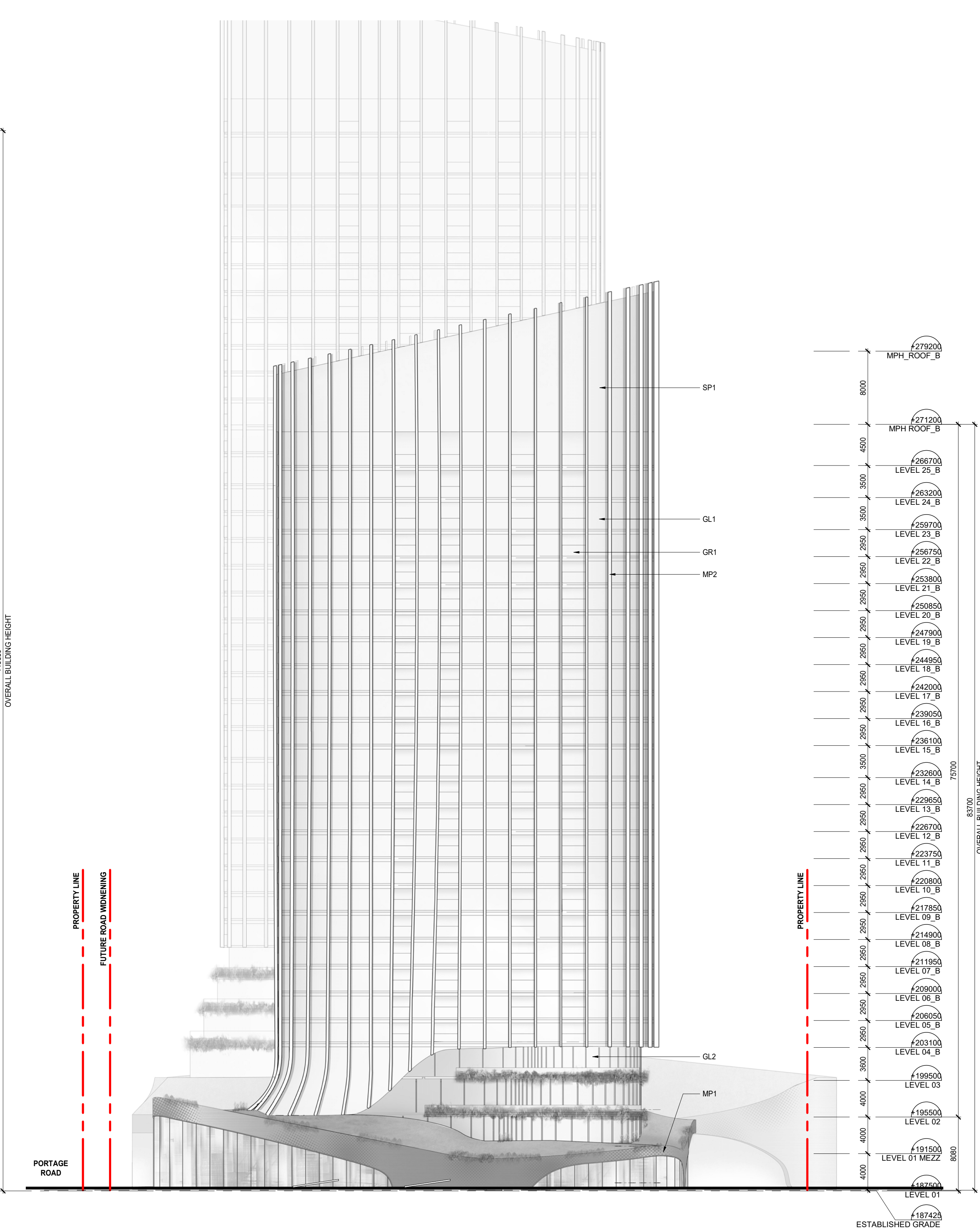

2 SOUTH ELEVATION  
A2.03 1:300

1 ISSUED FOR OPA/REZONING 2022-07-06

Revision Date

**giannone  
petricone  
associates**

Giannone Petricone Associates Inc. Architects  
462 Wellington Street West, Toronto, Canada M5V 1E3,  
T 416.591.7788 F 416.591.1293 E mail@gpaia.com

**RUDANCO INC.**

**PORTAGE RD**

LOT 175 PORTAGE ROAD, CITY OF NIAGARA FALLS,  
ONTARIO

SHEET TITLE

**ELEVATIONS**

DRAWN BY: TW  
CHECKED BY: KL  
PROJECT START DATE: 21-10-01  
PROJECT NO.: 21140  
SHEET NUMBER

**A2.03**



All drawings, specifications, related documents and design are the copyright property of the architect and must be returned upon request. Reproduction of the drawings, specifications, related documents and design in whole or in part is strictly forbidden without the architect's written permission.

**NOT FOR CONSTRUCTION**

**PRELIMINARY**

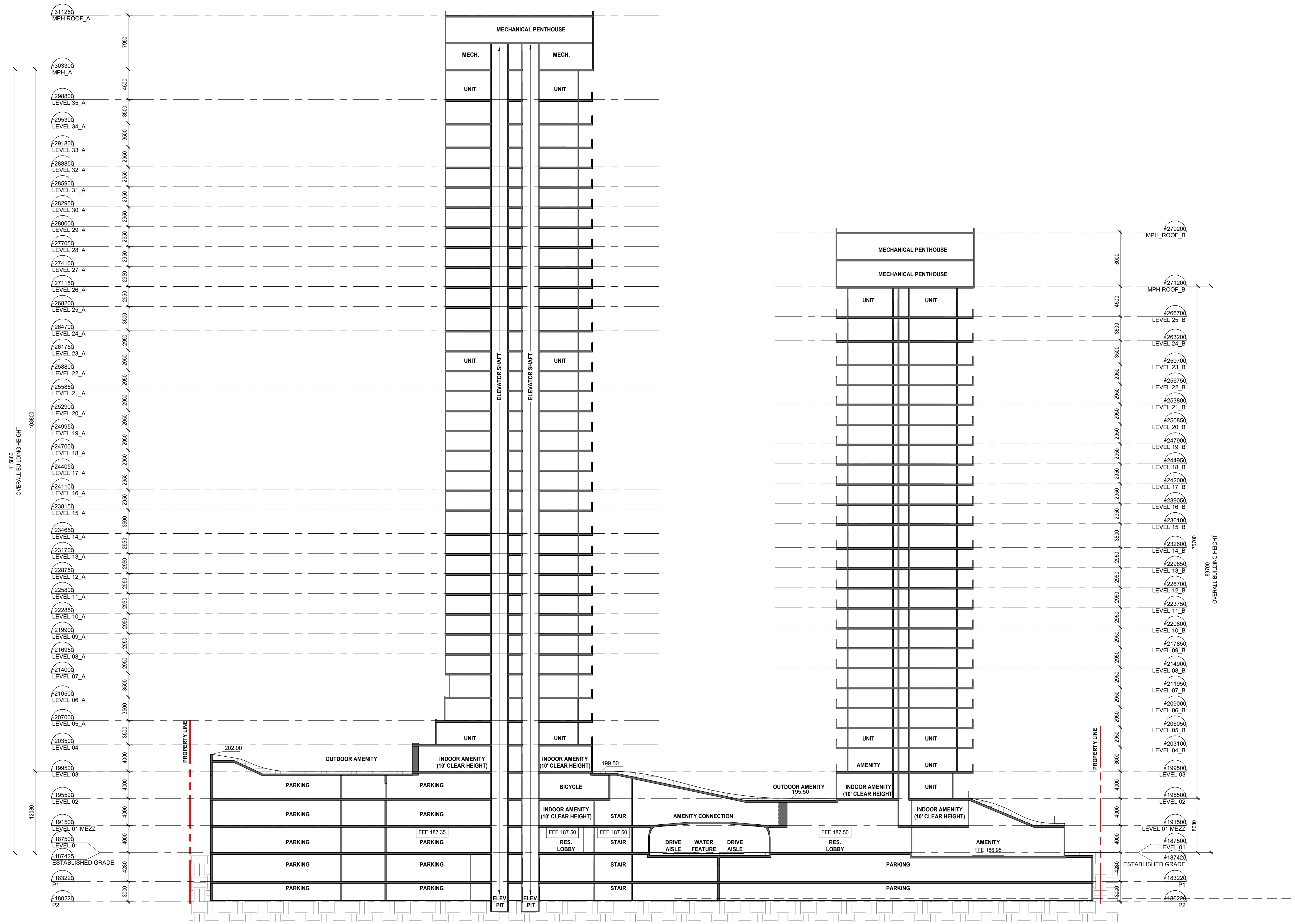

1 EW SECTION  
A3.01 1:300

1 ISSUED FOR OPA/REZONING 2022-07-06

Revision Date

**giannone  
petricone  
associates**

Giannone Petricone Associates Inc. Architects  
462 Wellington Street West, Toronto, Canada M5V 1E3,  
T 416.591.7788 F 416.591.1293 E mail@gpaia.com

**RUDANCO INC.**

**PORTAGE RD**

LOT 175 PORTAGE ROAD, CITY OF NIAGARA FALLS,  
ONTARIO

SHEET TITLE

**SECTION**

DRAWN BY: TW  
CHECKED BY: KL  
PROJECT START DATE: 21-10-01  
PROJECT NO.: 21140  
SHEET NUMBER

**A3.01**



**NOT FOR CONSTRUCTION**

**PRELIMINARY**

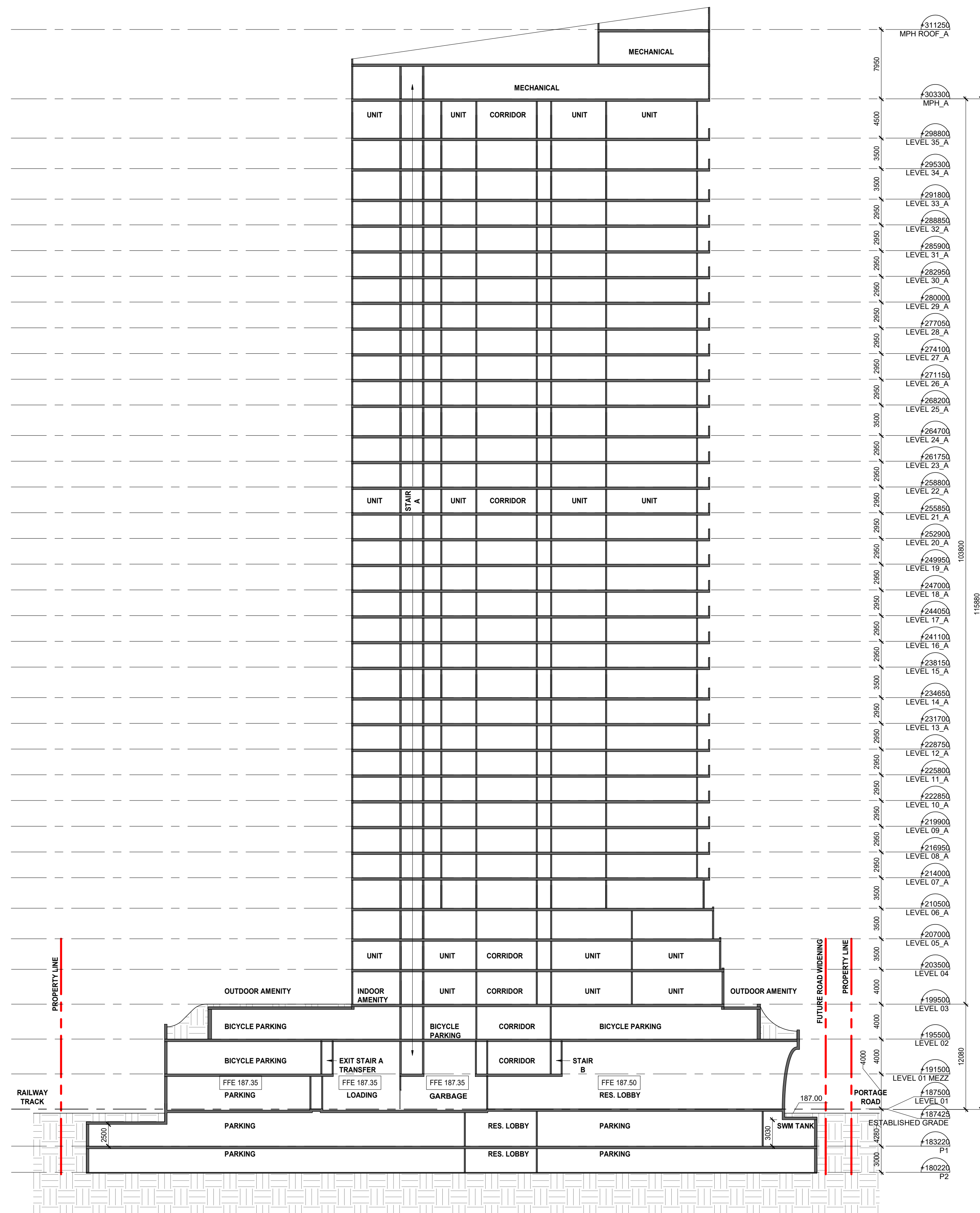

1 NS SECTION AT TOWER A  
A3.02 1:300

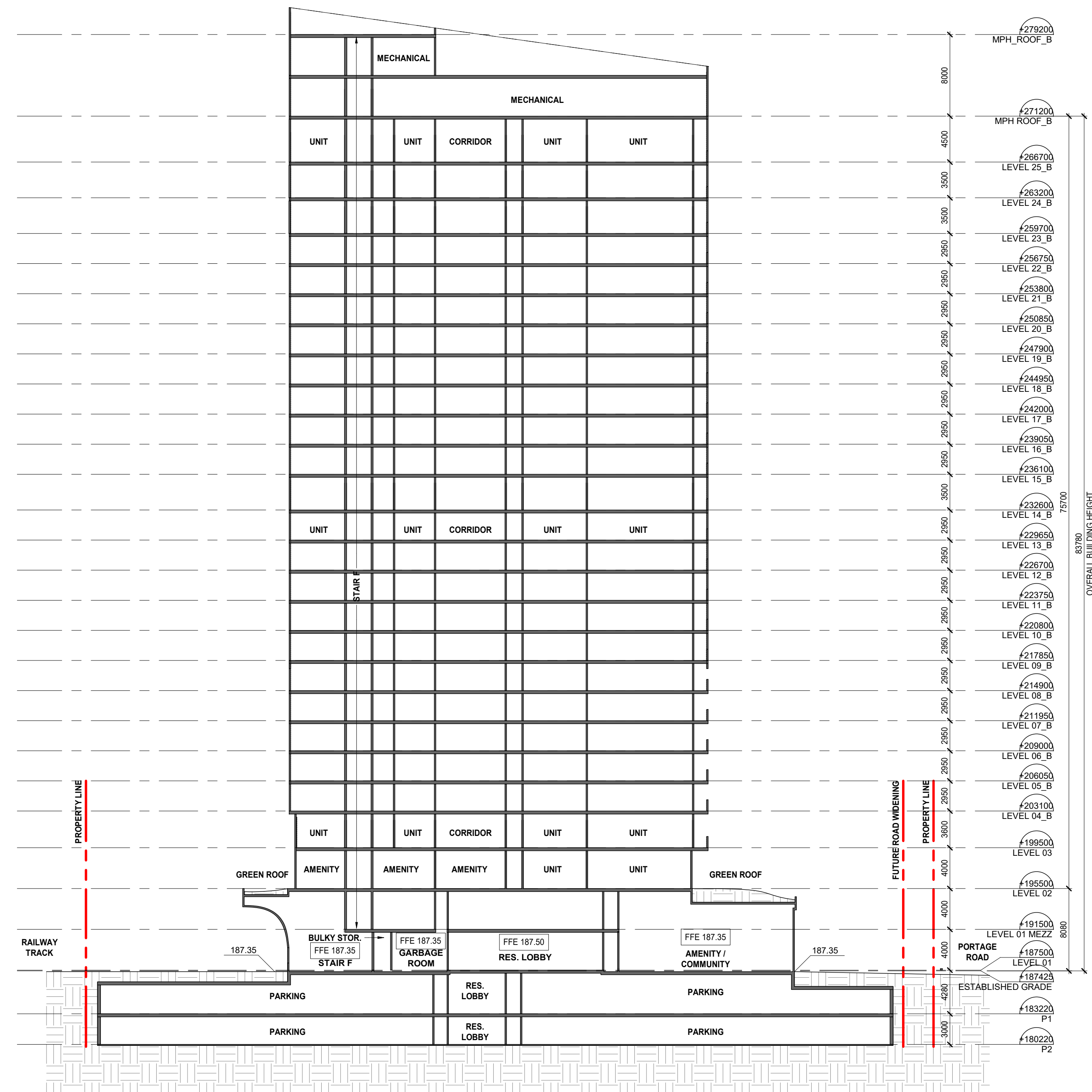

2 NS SECTION AT TOWER B  
A3.02 1:300

1 ISSUED FOR OPA/REZONING 2022-07-06  
Revision Date

**giannone  
petricone  
associates**

Giannone Petricone Associates Inc. Architects  
462 Wellington Street West, Toronto, Canada M5V 1E3,  
T 416.591.7788 F 416.591.1293 E mail@gpaia.com

**RUDANCO INC.**

**PORTAGE RD**

LOT 175 PORTAGE ROAD, CITY OF NIAGARA FALLS,  
ONTARIO

SECTIONS

DRAWN BY: TW  
CHECKED BY: KL  
PROJECT START DATE: 21-10-01  
PROJECT NO.: 21140  
SHEET NUMBER

**A3.02**





AERIAL VIEW TOWARD NIAGARA FALLS (RENDERING CONCEPT)

All drawings, specifications, related documents and design are the copyright property of the architect and must be returned upon request. Reproduction of the drawings, specifications, related documents and design in whole or in part is strictly forbidden without the architect's written permission.

**NOT FOR  
CONSTRUCTION**

**PRELIMINARY**

Revision	Date
1	ISSUED FOR OPA/REZONING 2022-07-06

**giannone  
petricone  
associates**

Giannone Petricone Associates Inc. Architects  
462 Wellington Street West, Toronto, Canada M5V 1E3,  
T 416.591.7788 F 416.591.1293 E mail@gpaia.com

**RUDANCO INC.**

**PORTAGE RD**

LOT 175 PORTAGE ROAD, CITY OF NIAGARA FALLS,  
ONTARIO

SHEET TITLE

**RENDERING**

DRAWN BY:	TW
CHECKED BY:	KL
PROJECT START DATE:	21-10-01
PROJECT NO.:	21140
SHEET NUMBER	

**A4.01**





AERIAL VIEW FROM THE EAST (RENDERING CONCEPT)

All drawings, specifications, related documents and design are the copyright property of the architect and must be returned upon request. Reproduction of the drawings, specifications, related documents and design in whole or in part is strictly forbidden without the architect's written permission.

**NOT FOR  
CONSTRUCTION**

**PRELIMINARY**

Revision	Date
1	ISSUED FOR OPA/REZONING 2022-07-06

**giannone  
petricone  
associates**

Giannone Petricone Associates Inc. Architects  
462 Wellington Street West, Toronto, Canada M5V 1E3,  
T 416.591.7788 F 416.591.1293 E mail@gpaia.com

**RUDANCO INC.**

**PORTAGE RD**

LOT 175 PORTAGE ROAD, CITY OF NIAGARA FALLS,  
ONTARIO

SHEET TITLE

**RENDERING**

DRAWN BY:	TW
CHECKED BY:	KL
PROJECT START DATE:	21-10-01
PROJECT NO.:	21140
SHEET NUMBER	

**A4.02**



All drawings, specifications, related documents and design are the copyright property of the architect and must be returned upon request. Reproduction of the drawings, specifications, related documents and design in whole or in part is strictly forbidden without the architect's written permission.

**NOT FOR  
CONSTRUCTION**

**PRELIMINARY**



PEDESTRIAN VIEW ALONG PORTAGE ROAD (RENDERING CONCEPT)

Revision	Date
1 ISSUED FOR OPA/REZONING	2022-07-06

**giannone  
petricone  
associates**

Giannone Petricone Associates Inc. Architects  
462 Wellington Street West, Toronto, Canada M5V 1E3,  
T 416.591.7788 F 416.591.1293 E mail@gpaia.com

**RUDANCO INC.**

**PORTAGE RD**

LOT 175 PORTAGE ROAD, CITY OF NIAGARA FALLS,  
ONTARIO

SHEET TITLE

**RENDERING**

DRAWN BY:	TW
CHECKED BY:	KL
PROJECT START DATE:	21-10-01
PROJECT NO.:	21140
SHEET NUMBER	

**A4.03**



**NOT FOR  
CONSTRUCTION**

**PRELIMINARY**



PEDESTRIAN VIEW AT MAIN ENTRANCE (RENDERING CONCEPT)

Revision	Date
1	ISSUED FOR OPA/REZONING 2022-07-06

**giannone  
petricone  
associates**

Giannone Petricone Associates Inc. Architects  
462 Wellington Street West, Toronto, Canada M5V 1E3,  
T 416.591.7788 F 416.591.1293 E mail@gpaa.com

**RUDANCO INC.**

**PORTAGE RD**

LOT 175 PORTAGE ROAD, CITY OF NIAGARA FALLS,  
ONTARIO

SHEET TITLE

**RENDERING**

DRAWN BY:	TW
CHECKED BY:	KL
PROJECT START DATE:	21-10-01
PROJECT NO.:	21140
SHEET NUMBER	

**A4.04**



All drawings, specifications, related documents and design are the copyright property of the architect and must be returned upon request. Reproduction of the drawings, specifications, related documents and design in whole or in part is strictly forbidden without the architect's written permission.

**NOT FOR  
CONSTRUCTION**

**PRELIMINARY**



PODIUM OUTDOOR AMENITY (RENDERING CONCEPT)

Revision	Date
1	ISSUED FOR OPA/REZONING 2022-07-06

**giannone  
petricone  
associates**

Giannone Petricone Associates Inc. Architects  
462 Wellington Street West, Toronto, Canada M5V 1E3,  
T 416.591.7788 F 416.591.1293 E mail@gpaa.com

**RUDANCO INC.**

**PORTAGE RD**

LOT 175 PORTAGE ROAD, CITY OF NIAGARA FALLS,  
ONTARIO

SHEET TITLE

**RENDERING**

DRAWN BY:	Author
CHECKED BY:	Checker
PROJECT START DATE:	21-10-01
PROJECT NO.:	21140
SHEET NUMBER	

**A4.05**



**NOT FOR  
CONSTRUCTION**

**PRELIMINARY**

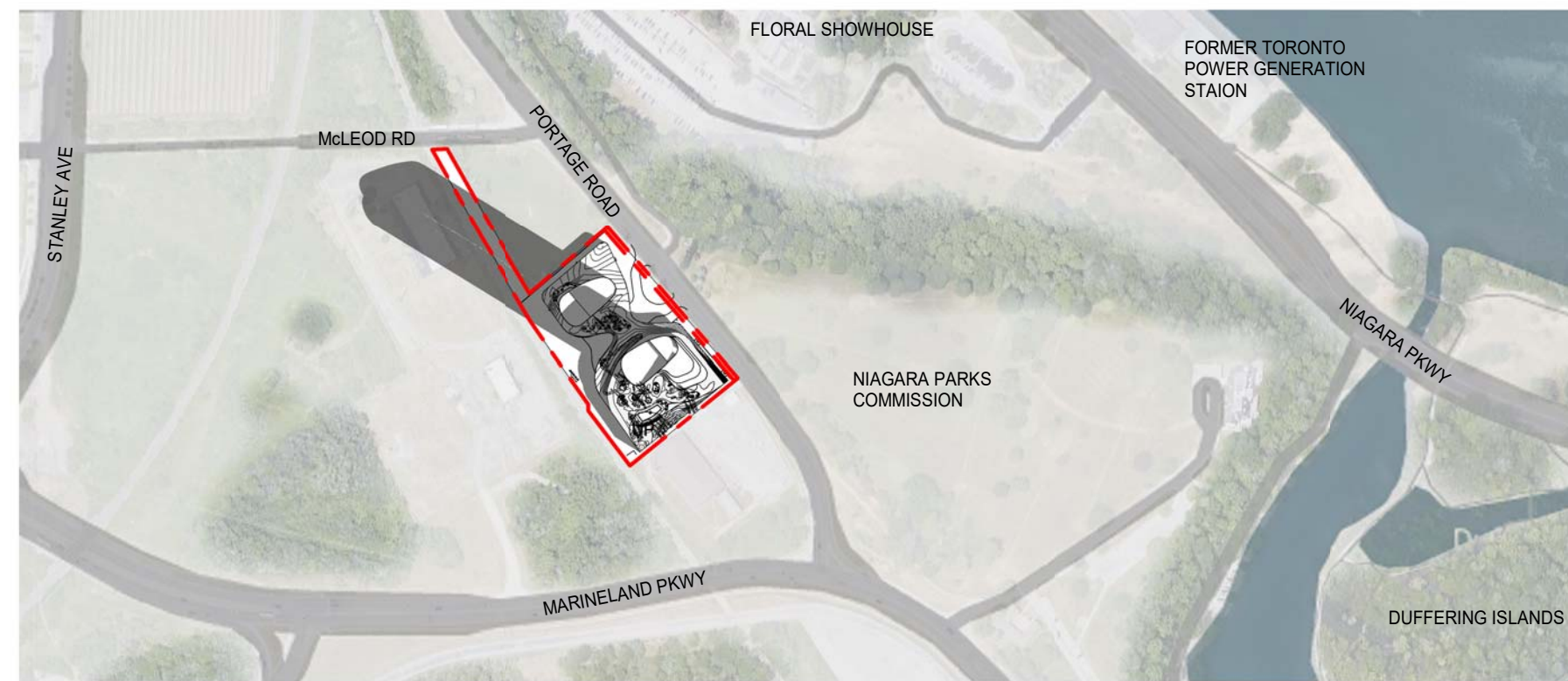

10:00 a.m.  
SCALE 1:4500

SEPTEMBER 21

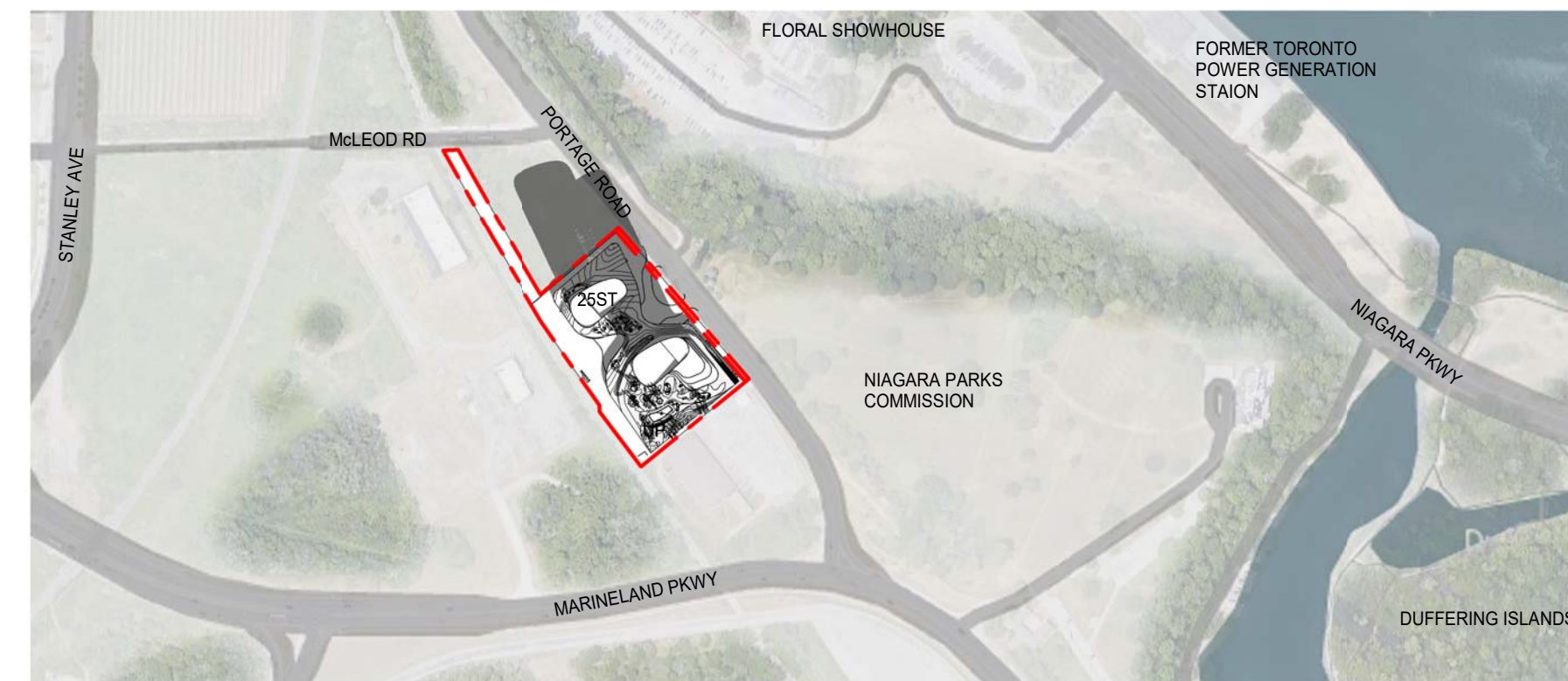

12:00 p.m.  
SCALE 1:4500

SEPTEMBER 21

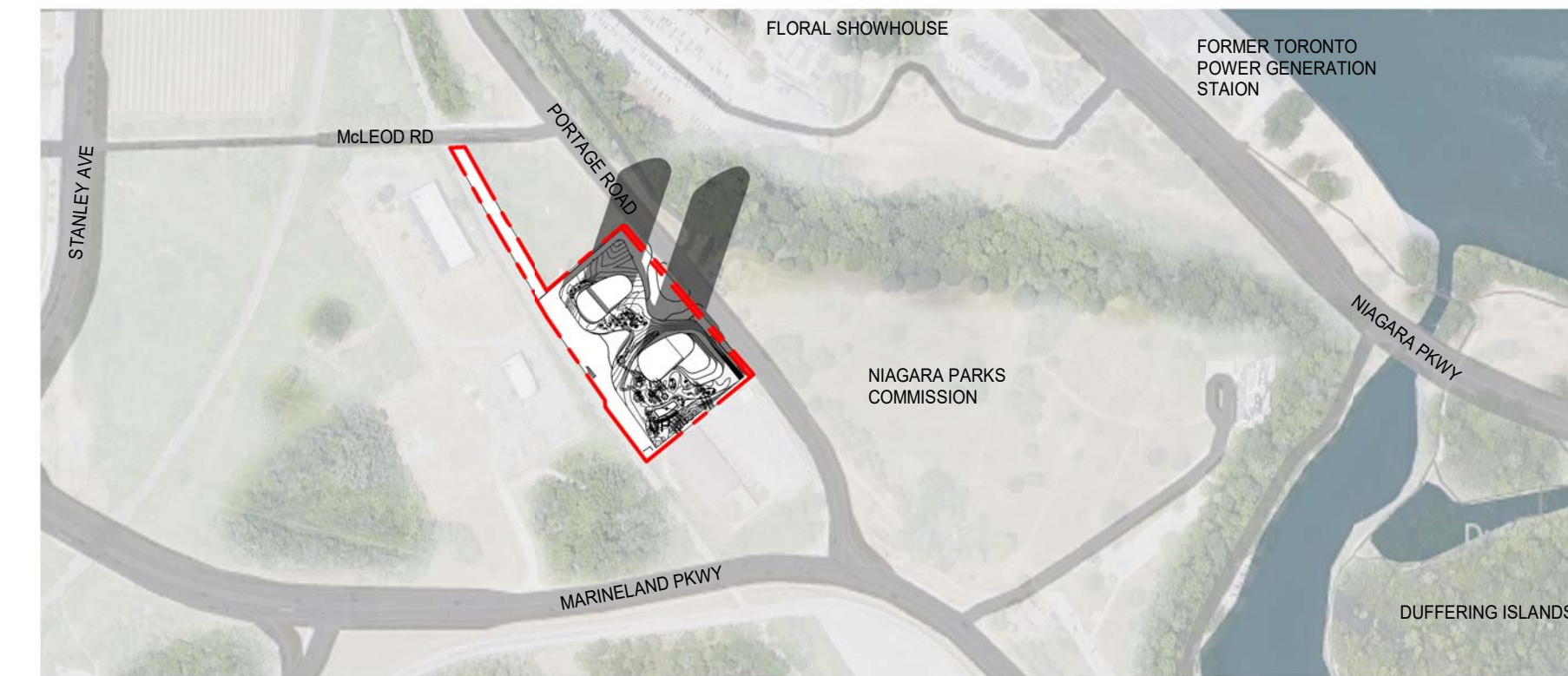

2:00 p.m.  
SCALE 1:4500

SEPTEMBER 21

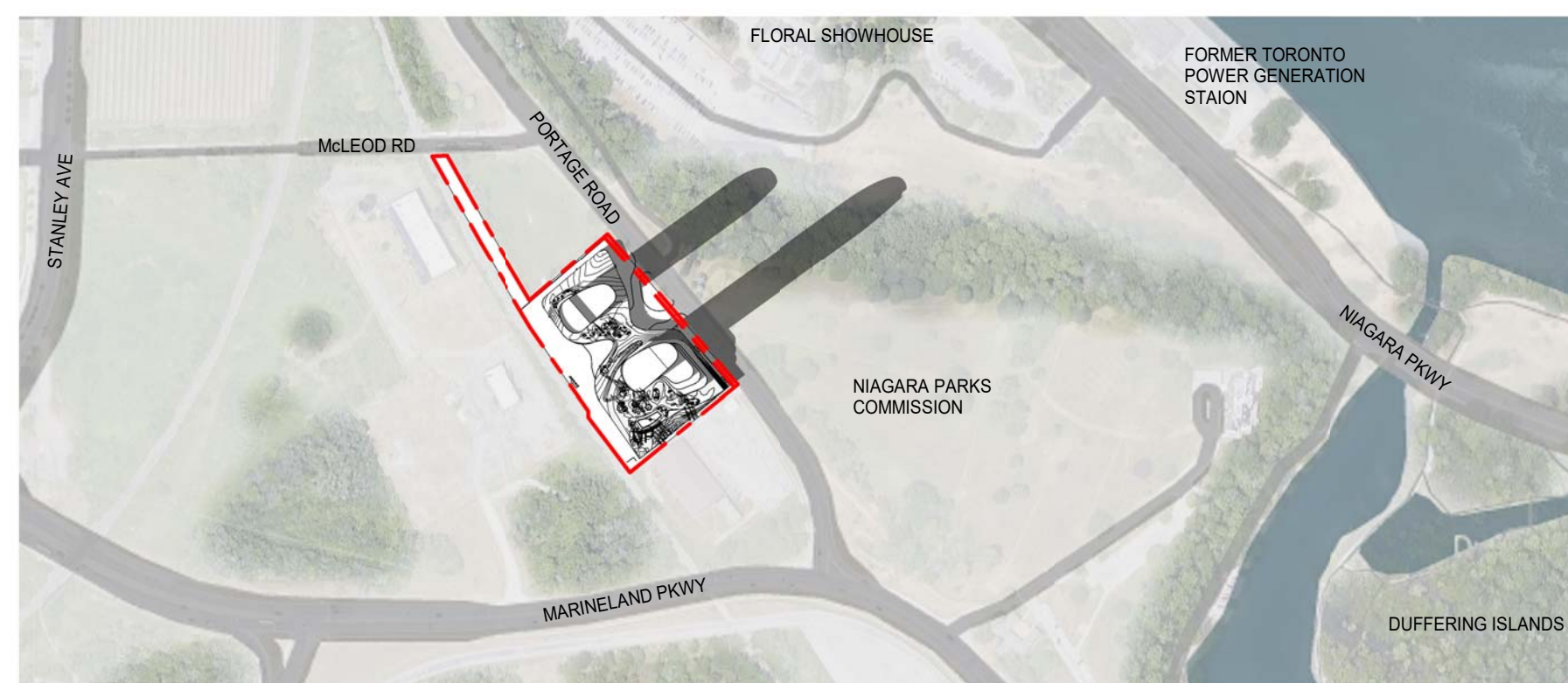

4:00 p.m.  
SCALE 1:4500

SEPTEMBER 21

- NEW SHADOW BY PROPOSED BUILDING
- PROPERTY LINE

Revision	Date
1	ISSUED FOR OPA/REZONING 2022-07-06

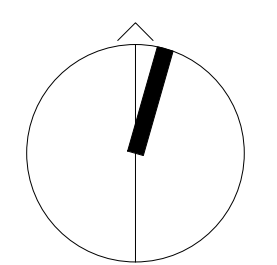

**giannone  
petricone  
associates**

Giannone Petricone Associates Inc. Architects  
462 Wellington Street West, Toronto, Canada M5V 1E3,  
T 416.591.7788 F 416.591.1293 E mail@gpaa.com

**RUDANCO INC.**

**PORTAGE RD**

LOT 175 PORTAGE ROAD, CITY OF NIAGARA FALLS,  
ONTARIO

SHEET TITLE

SHADOW STUDY

DRAWN BY:	TW
CHECKED BY:	KL
PROJECT START DATE:	21-10-01
PROJECT NO.:	21140
SHEET NUMBER	

**A5.01**



**NOT FOR  
CONSTRUCTION**

**PRELIMINARY**

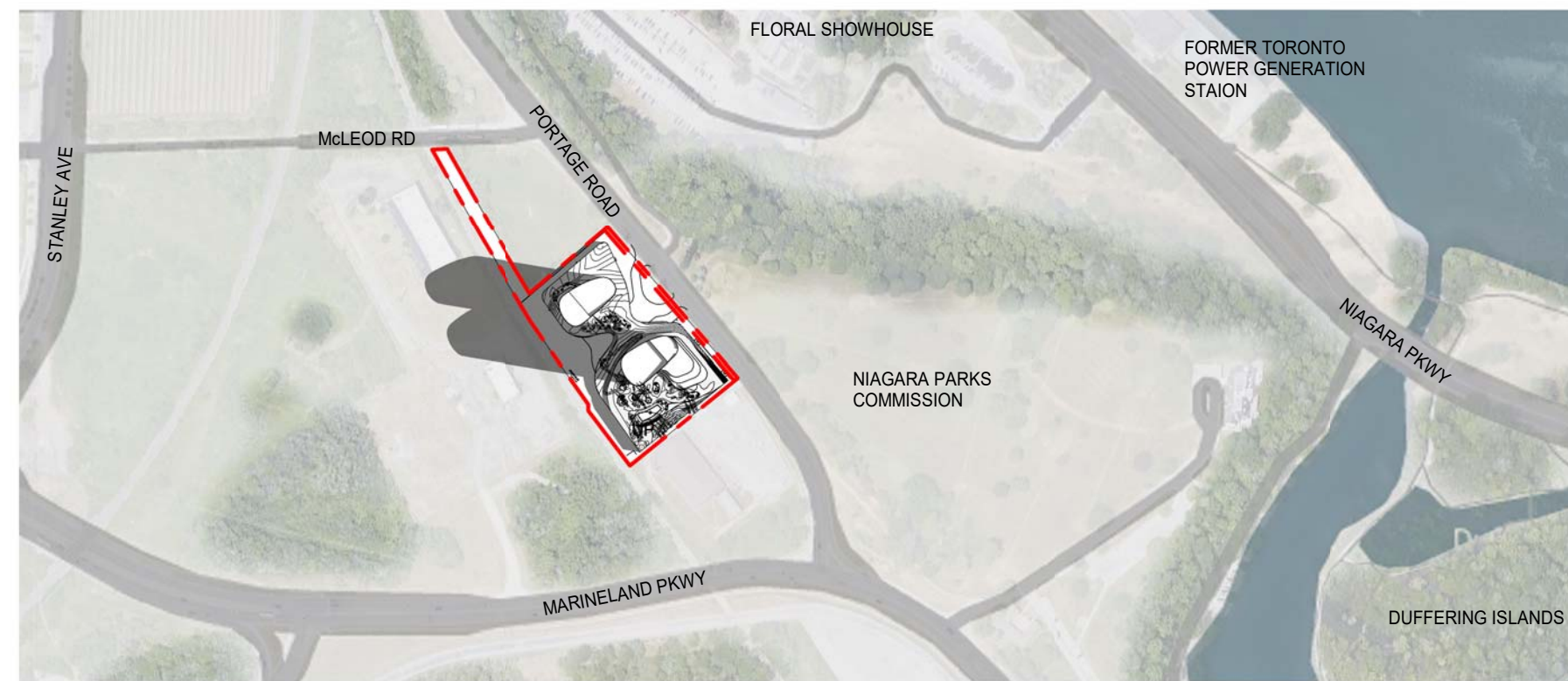

10:00 a.m  
SCALE 1:4500

JUNE 21

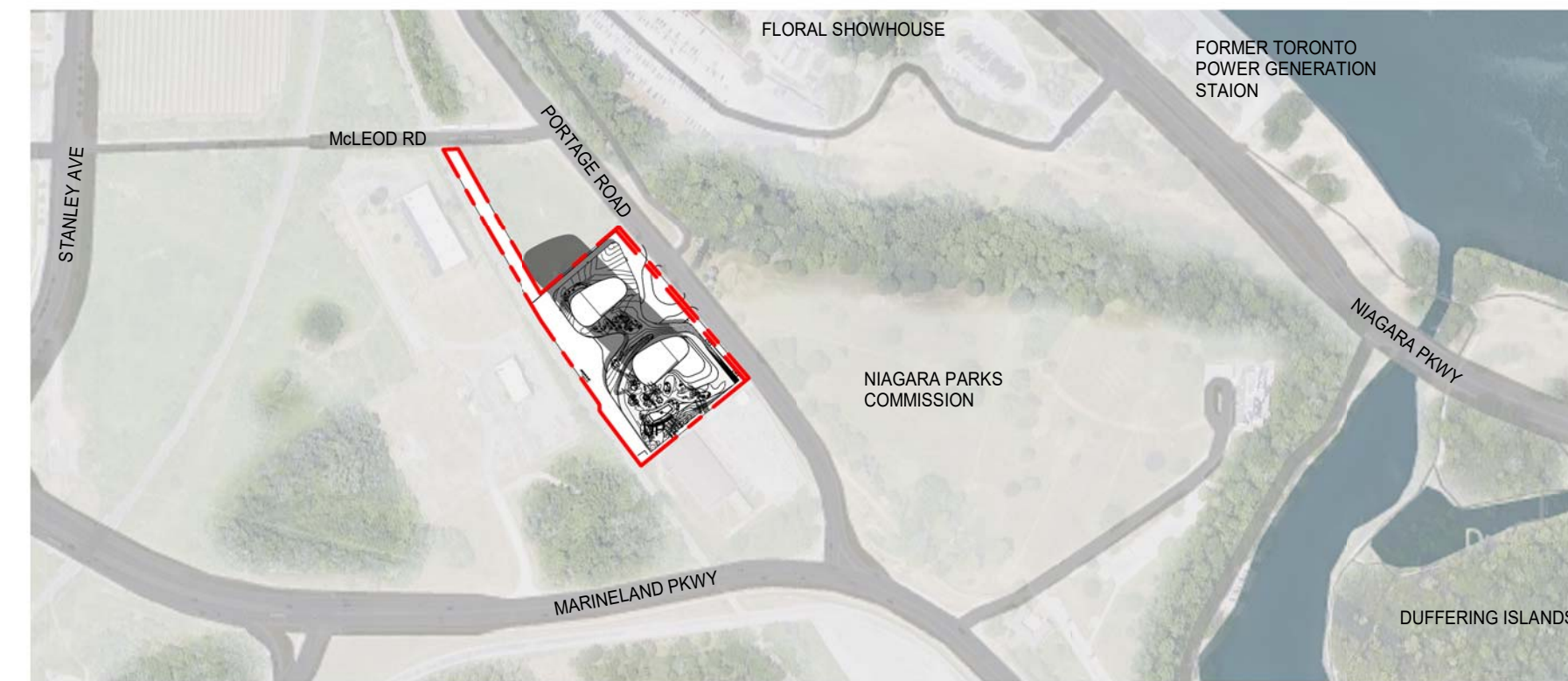

12:00 p.m  
SCALE 1:4500

JUNE 21

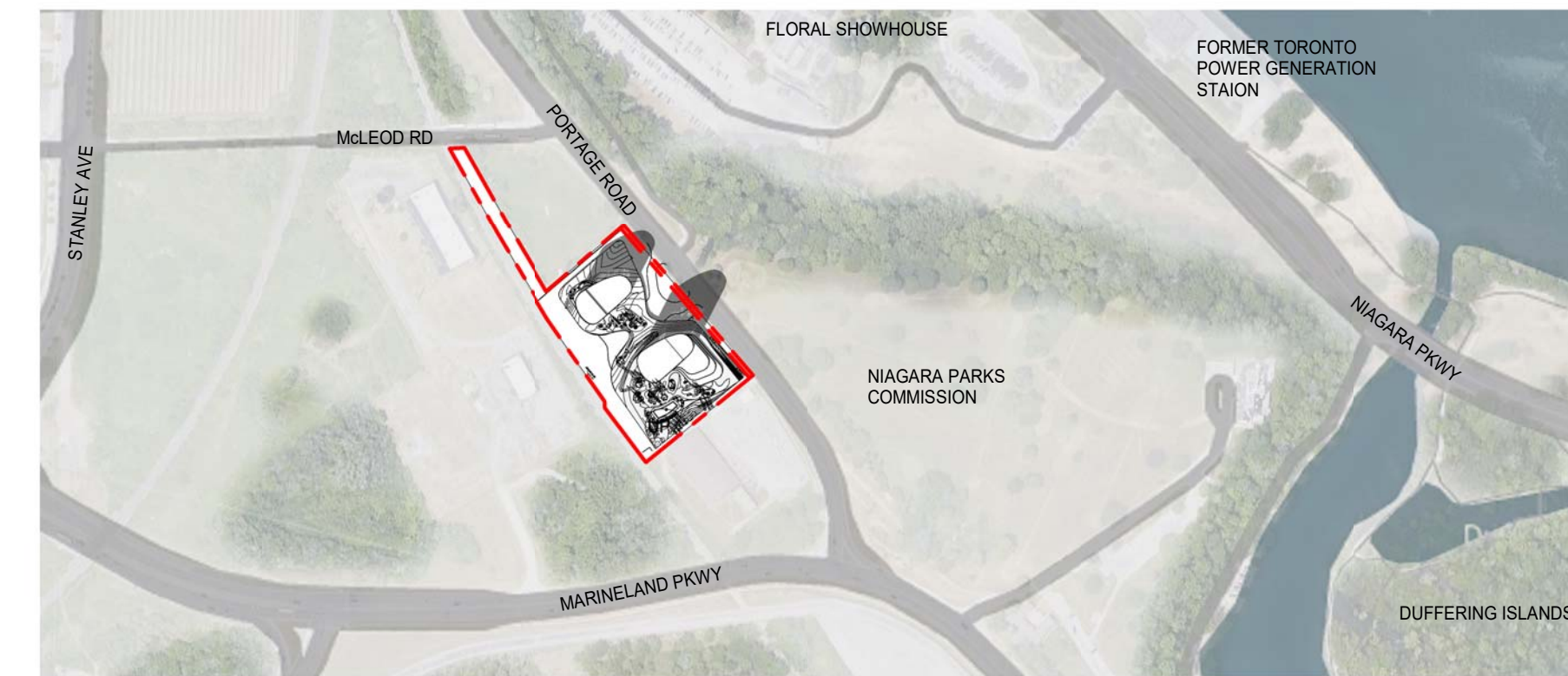

2:00 p.m  
SCALE 1:4500

JUNE 21

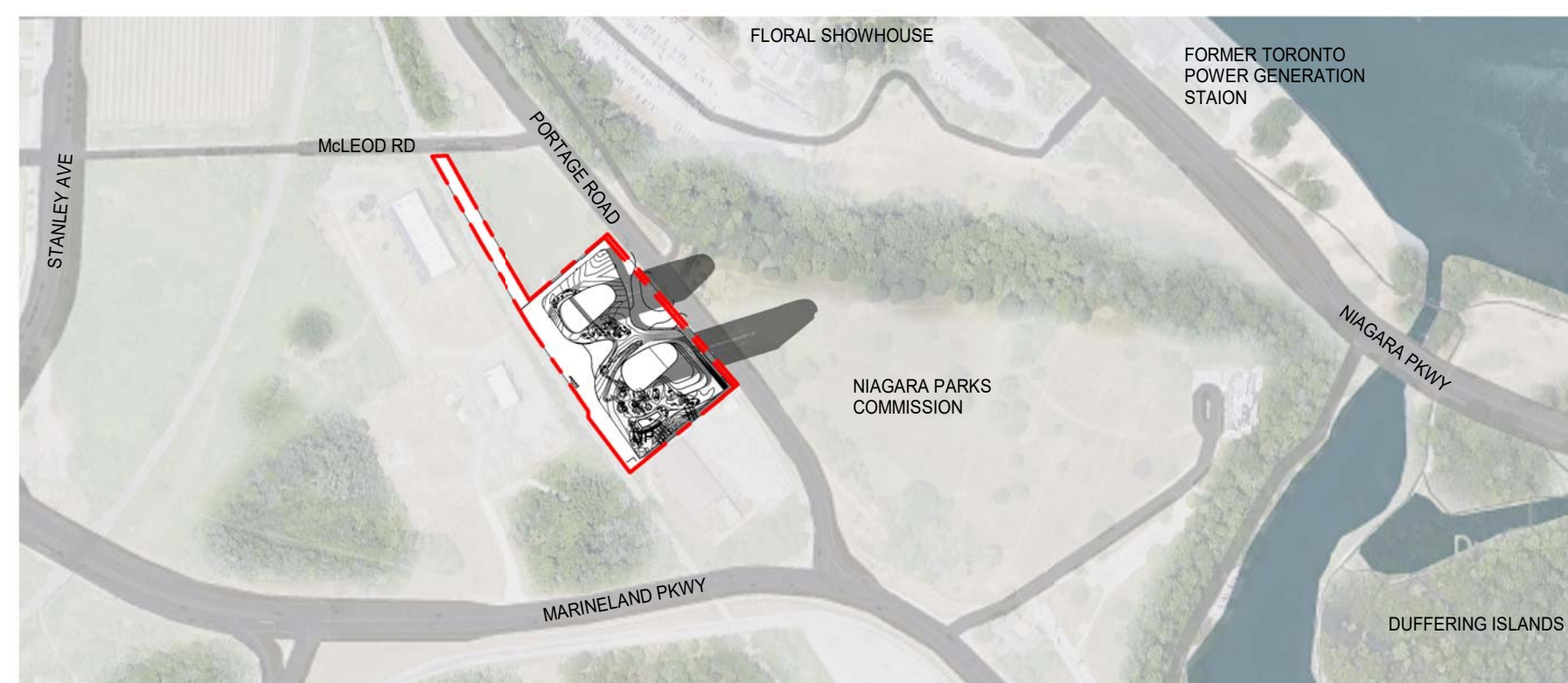

4:00 p.m  
SCALE 1:4500

JUNE 21

- NEW SHADOW BY PROPOSED BUILDING
- PROPERTY LINE

Revision	Date
1	ISSUED FOR OPA/REZONING 2022-07-06

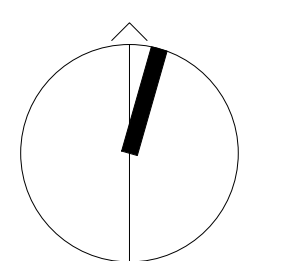

**giannone  
petricone  
associates**

Giannone Petricone Associates Inc. Architects  
462 Wellington Street West, Toronto, Canada M5V 1E3,  
T 416.591.7788 F 416.591.1293 E mail@gpaa.com

RUDANCO INC.

PORTAGE RD

LOT 175 PORTAGE ROAD, CITY OF NIAGARA FALLS,  
ONTARIO

SHEET TITLE

SHADOW STUDY

DRAWN BY:	TW
CHECKED BY:	KL
PROJECT START DATE:	21-10-01
PROJECT NO.:	21140
SHEET NUMBER	

**A5.02**