

**PEDESTRIAN LEVEL  
WIND STUDY**

7701 Lundy's Lane  
Niagara Falls, Ontario

Report: 24-147-PLW



July 29, 2024

PREPARED FOR  
100706636 Ontario Inc.  
PO Box 870  
Niagara-on-the-Lake, ON L0S 1J0

PREPARED BY  
Sunny Kang, B.A.S., Project Coordinator  
Omar Rioseco, B.Eng., Junior Wind Scientist  
David Huitema, M.Eng., P.Eng., CFD Lead Engineer

## **EXECUTIVE SUMMARY**

This report describes a pedestrian level wind (PLW) study to satisfy concurrent Official Plan Amendment (OPA) and Zoning By-Law Amendment (ZBLA) application requirements for the proposed residential development located at 7701 Lundy's Lane in Niagara Falls, Ontario (hereinafter referred to as the "subject site" or "proposed development"). Our mandate within this study is to investigate pedestrian wind conditions within and surrounding the subject site, and to identify areas where wind conditions may interfere with certain pedestrian activities so that mitigation measures may be considered, where required.

The study involves simulation of wind speeds for sixteen (16) wind directions in a three-dimensional (3D) computer model using the computational fluid dynamics (CFD) technique, combined with meteorological data integration, to assess pedestrian wind comfort and safety within and surrounding the subject site. A complete summary of the predicted wind conditions is provided in Section 5 and illustrated in Figures 3A-4B, and is summarized as follows:

- 1) All grade-level areas within and surrounding the subject site are predicted to experience conditions that are considered acceptable for the intended pedestrian uses throughout the year. Specifically, conditions over surrounding sidewalks, transit stops, neighbouring existing surface parking lots, the landscape amenities, and in the vicinity of building access points, are considered acceptable.
- 2) The foregoing statements and conclusions apply to common weather systems, during which no dangerous wind conditions, as defined in Section 4.4, are expected over the subject site. During extreme weather events, (for example, thunderstorms, tornadoes, and downbursts), pedestrian safety is the main concern. However, these events are generally short-lived and infrequent and there is often sufficient warning for pedestrians to take appropriate cover.



**TABLE OF CONTENTS**

**1. INTRODUCTION ..... 1**

**2. TERMS OF REFERENCE ..... 1**

**3. OBJECTIVES ..... 2**

**4. METHODOLOGY ..... 2**

**4.1 Computer-Based Context Modelling .....3**

**4.2 Wind Speed Measurements.....3**

**4.3 Historical Wind Speed and Direction Data .....4**

**4.4 Pedestrian Wind Comfort and Safety Criteria – City of Niagara Falls.....6**

**5. RESULTS AND DISCUSSION ..... 8**

**5.1 Wind Comfort Conditions – Grade Level.....8**

**5.2 Wind Safety .....10**

**5.3 Applicability of Results .....10**

**6. SUMMARY AND RECOMMENDATIONS ..... 11**

**FIGURES**

**APPENDICES**

**Appendix A – Simulation of the Atmospheric Boundary Layer**



## **1. INTRODUCTION**

Gradient Wind Engineering Inc. (Gradient Wind) was retained by 100706636 Ontario Inc. to undertake a pedestrian level wind (PLW) study to satisfy concurrent Official Plan Amendment (OPA) and Zoning By-Law Amendment (ZBLA) application requirements for the proposed residential development located at 7701 Lundy's Lane in Niagara Falls, Ontario (hereinafter referred to as the "subject site" or "proposed development"). Our mandate within this study is to investigate wind conditions within and surrounding the subject site, and to identify areas where wind conditions may interfere with certain pedestrian activities so that mitigation measures may be considered, where required.

The study is based on industry standard computer simulations using the computational fluid dynamics (CFD) technique and data analysis procedures, wind comfort and safety criteria for the City of Niagara Falls, architectural drawings provided by MZE Architects Inc. in July 2024, surrounding street layouts and existing and approved future building massing information obtained from the City of Niagara Falls, and recent site imagery.

## **2. TERMS OF REFERENCE**

The subject site is located at 7701 Lundy's Lane in Niagara Falls, situated to the northwest at the intersection of Lundy's Lane and Beaverdams Road on a near triangular parcel of land bordered by Beaverdams Road to the east, Lundy's Lane to the south, and an existing low-rise hotel building with a surface parking lot to the west. The subject site includes an existing low-rise hotel building along the west, north, and east sides of the subject site and a central surface parking lot which is to be retained. The proposed development is located to the south of the subject site, fronting Lundy's Lane, and comprises a rectangular 6-storey residential building.

The ground floor of the proposed development includes a central lobby and elevator core with main entrances to the north and south, an indoor amenity to the west, a secondary entrance and a stairwell at the northwest corner, a stairwell at the northeast corner, and an indoor amenity and a bicycle storage to the east. Landscape amenities are proposed nearly central to the subject site, replacing the existing swimming pool, and to the east of the proposed development. Additional surface parking is provided along the rear north elevation of the proposed development at grade. Levels 2-6 rise with a rectangular planform and are programmed for residential occupancy.



Regarding wind exposures, the near-field surroundings of the subject site (defined as an area falling within a 200-metre (m) radius of the subject site) are characterized by a mix of low-rise hotel and commercial buildings with surface parking lots from the east clockwise to the west and low-rise residential dwellings from the northwest clockwise to the northeast, with green space further to the south. Notably, Lundy's Lane Cemetery is located approximately 150 m to the east of the proposed development. The far-field surroundings (defined as the area beyond the near field and within a two-kilometre (km) radius) comprise low-rise suburban massing in all compass directions, with green space further to the northwest, Charnwood Park approximately 1.3 km to the south, and isolated mid-rise buildings to the northeast, east, and south. The Hydro Canal flows from the south-southeast to the northeast, approximately 775 m to the east of the proposed development.

Figure 1A illustrates the subject site and surrounding context, representing the proposed future massing scenario, while Figure 1B illustrates the subject site and surrounding context, representing the existing massing scenario. Figures 2A-2H illustrate the computational models used to conduct the study.

### **3. OBJECTIVES**

The principal objectives of this study are to (i) determine pedestrian level wind conditions at key areas within and surrounding the subject site; (ii) identify areas where wind conditions may interfere with the intended uses of outdoor spaces; and (iii) recommend suitable mitigation measures, where required.

### **4. METHODOLOGY**

The approach followed to quantify wind conditions over the site is based on CFD simulations of wind speeds across the subject site within a virtual environment, meteorological analysis of the Niagara Falls area wind climate, and synthesis of computational data with City of Niagara Falls wind criteria<sup>1</sup>. The following sections describe the analysis procedures, including a discussion of the noted pedestrian wind criteria.

---

<sup>1</sup> City of Niagara Falls, *Pedestrian Level Wind Study Terms of Reference Guide*, August 2023



#### 4.1 Computer-Based Context Modelling

A computer based PLW study was performed to determine the influence of the wind environment on pedestrian comfort over the proposed development site. Pedestrian comfort predictions, based on the mechanical effects of wind, were determined by combining measured wind speed data from CFD simulations with statistical weather data obtained from the Niagara Falls International Airport in Niagara Falls, New York. The general concept and approach to CFD modelling is to represent building and topographic details in the immediate vicinity of the subject site on the surrounding model, and to create suitable atmospheric wind profiles at the model boundary. The wind profiles are designed to have similar mean and turbulent wind properties consistent with actual site exposures.

An industry standard practice is to omit trees, vegetation, and other existing and proposed landscape elements from the model due to the difficulty of providing accurate seasonal representation of vegetation. The omission of trees and other landscaping elements produces stronger wind speed values.

#### 4.2 Wind Speed Measurements

The PLW analysis was performed by simulating wind flows and gathering velocity data over a CFD model of the subject site for 16 wind directions. The CFD simulation model was centered on the proposed development, complete with surrounding massing within a radius of 480 m. The process was performed for two context massing scenarios, as noted in Section 2.

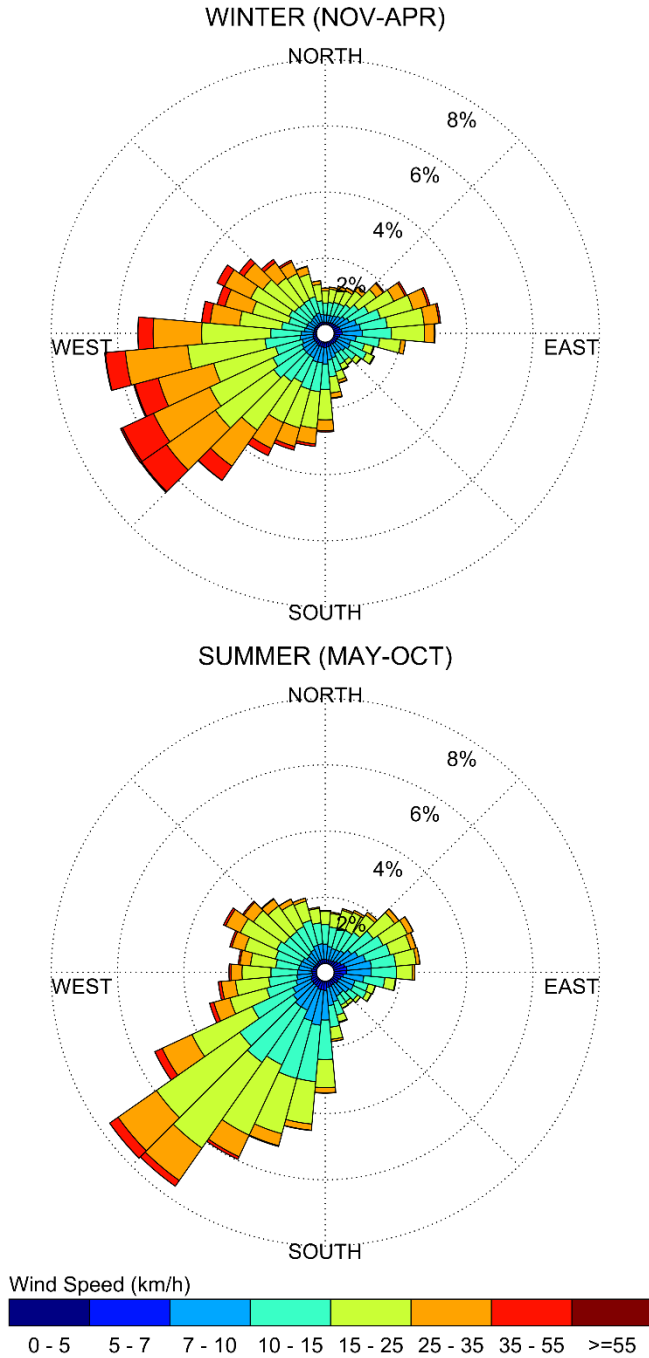
Mean and peak wind speed data obtained over the subject site for each wind direction were interpolated to 36 wind directions at 10° intervals, representing the full compass azimuth. Measured wind speeds approximately 1.5 m above local grade were referenced to the wind speed at gradient height to generate mean and peak velocity ratios, which were used to calculate full-scale values. Gradient height represents the theoretical depth of the boundary layer of the earth's atmosphere, above which the mean wind speed remains constant. Further details of the wind flow simulation technique are presented in Appendix A.

### 4.3 Historical Wind Speed and Direction Data

A statistical model for winds in Niagara Falls was developed from approximately 40 years of hourly meteorological wind data recorded at Niagara Falls International Airport. Wind speed and direction data were analyzed during the appropriate hours of pedestrian usage (that is, between 06:00 and 23:00) and divided into two distinct seasons, as stipulated in the wind criteria. Specifically, the summer season is defined as May through October, and the winter season is defined as November through April, inclusive.

The statistical model of the Niagara Falls area wind climate, which indicates the directional character of local winds on a seasonal basis, is illustrated on the following page. The plots illustrate seasonal distribution of measured wind speeds and directions in kilometers per hour (km/h). Probabilities of occurrence of different wind speeds are represented as stacked polar bars in sixteen azimuth divisions. The radial direction represents the percentage of time for various wind speed ranges per wind direction during the measurement period. The preferred wind speeds and directions can be identified by the longer length of the bars. For Niagara Falls, the most common winds occur for southwesterly wind directions, followed by those from the northwest and northeast, while the most common wind speeds are below 36 km/h. The directional preference and relative magnitude of wind speed changes somewhat between summer and winter.

**SEASONAL DISTRIBUTION OF WIND  
NIAGARA FALLS INTERNATIONAL AIRPORT, NIAGARA FALLS, NEW YORK**



**Notes:**

1. Radial distances indicate percentage of time of wind events.
2. Wind speeds are mean hourly in km/h, measured at 10 m above the ground.



#### 4.4 Pedestrian Wind Comfort and Safety Criteria – City of Niagara Falls

Pedestrian wind comfort and safety criteria are based on the mechanical effects of wind without consideration of other meteorological conditions (that is, temperature and relative humidity). The comfort criteria assume that pedestrians are appropriately dressed for a specified outdoor activity during any given season. Since both mean and gust wind speeds affect pedestrian comfort, their combined effect is defined in the City of Niagara Falls Pedestrian Level Wind Study Terms of Reference Guide. Specifically, the criteria are defined as a Gust Equivalent Mean (GEM) wind speed, which is the greater of the mean wind speed or the gust wind speed divided by 1.85.

The wind speed ranges are based on the Beaufort scale, which describes the effects of forces produced by varying wind speed levels on objects. Four pedestrian comfort classes and corresponding gust wind speed ranges are used to assess pedestrian comfort: (1) Sitting; (2) Standing; (3) Walking; and (4) Uncomfortable. Wind conditions suitable for sitting are represented by the colour blue, standing by green, and walking by yellow; uncomfortable conditions are represented by the colour orange, consistent with the City of Niagara Falls Terms of Reference. Specifically, the comfort classes, associated wind speed ranges, and limiting criteria are summarized as follows:

##### PEDESTRIAN WIND COMFORT CLASS DEFINITIONS

Wind Comfort Class	GEM Speed (km/h)	Description
SITTING	≤ 10	GEM wind speeds no greater than 10 km/h occurring at least 80% of the time are considered acceptable for sedentary activities, including sitting.
STANDING	≤ 15	GEM wind speeds no greater than 15 km/h occurring at least 80% of the time are considered acceptable for activities such as standing, strolling, or more vigorous activities.
WALKING	≤ 20	GEM wind speeds no greater than 20 km/h occurring at least 80% of the time are considered acceptable for walking or more vigorous activities.
UNCOMFORTABLE	> 20	Uncomfortable conditions are characterized by predicted values that fall below the 80% target for walking. Brisk walking and exercise, such as jogging, are considered acceptable for moderate excesses of this criterion.



Regarding wind safety, gust wind speeds greater than 90 km/h, occurring more than 0.1% of the time on an annual basis (based on wind events recorded for 24 hours a day), are classified as dangerous. From calculations of stability, it can be shown that gust wind speeds of 90 km/h would be the approximate threshold wind speed that would cause an average elderly person in good health to fall.

Experience and research on people’s perception of mechanical wind effects has shown that if the wind speed levels are exceeded for more than 20% of the time, the activity level would be judged to be uncomfortable by most people. For instance, if GEM wind speeds of 10 km/h were exceeded for more than 20% of the time most pedestrians would judge that location to be too windy for sitting. Similarly, if GEM wind speeds of 20 km/h at a location were exceeded for more than 20% of the time, walking or less vigorous activities would be considered uncomfortable. As these criteria are based on subjective reactions of a population to wind forces, their application is partly based on experience and judgment.

Once the pedestrian wind speed predictions have been established throughout the subject site, the assessment of pedestrian comfort involves determining the suitability of the predicted wind conditions for discrete regions within and surrounding the subject site. This step involves comparing the predicted comfort classes to the target comfort classes, which are dictated by the location type for each region (that is, a sidewalk, building entrance, amenity space, or other). An overview of common pedestrian location types and their typical windiest target comfort classes are summarized below. Depending on the programming of a space, the desired comfort class may differ from this table.

**TARGET PEDESTRIAN WIND COMFORT CLASSES FOR VARIOUS LOCATION TYPES**

Location Types	Target Comfort Classes
Primary Building Entrance	Standing
Secondary Building Access Point	Walking
Public Sidewalk / Bicycle Path	Walking
Café / Patio / Bench / Garden	Sitting / Standing
Transit/Bus Stop (Without Shelter)	Standing
Transit/Bus Stop (With Shelter)	Walking
Public Park / Plaza / Amenity Space	Sitting / Standing
Garage / Service Entrance / Parking Lot	Walking

## 5. RESULTS AND DISCUSSION

The following discussion of the predicted pedestrian wind conditions for the subject site is accompanied by Figures 3A-4B, which illustrate wind conditions at grade level for the proposed and existing massing scenarios. Conditions are presented as continuous contours of wind comfort and correspond to the various comfort classes noted in Section 4.4.

The details of these conditions are summarized in the following pages for each area of interest.

### 5.1 Wind Comfort Conditions – Grade Level

**Sidewalks along Beaverdams Road:** Wind comfort conditions over the nearby public sidewalks along Beaverdams Road are predicted to be suitable for sitting during the summer, with regions suitable for standing near the intersection of Beaverdams Road and Lundy’s Lane, becoming suitable for standing, or better, during the winter, prior to and following the introduction of the proposed development. The noted conditions are considered acceptable.

**Sidewalks and Transit Stops along Lundy’s Lane:** Following the introduction of the proposed development, wind conditions over the nearby public sidewalks along Lundy’s Lane are predicted to be suitable for standing, or better, during the summer, becoming suitable for mostly standing during the winter, with isolated regions suitable for walking. Conditions in the vicinity of the nearby transit stops along Lundy’s Lane are predicted to be suitable for standing, or better, throughout the year. The noted conditions are considered acceptable.

Conditions along Lundy’s Lane under the existing massing are predicted to be suitable for standing, or better, during the summer, becoming suitable for standing during the winter, with isolated regions suitable for walking to the east. Under the existing massing, conditions in the vicinity of the nearby eastbound transit stop are predicted to be suitable for sitting during the summer, becoming suitable for standing during the winter, while conditions in the vicinity of the nearby westbound transit stop are predicted to be suitable for a mix of sitting and standing during the summer, becoming suitable for standing during the winter. While the introduction of the proposed development produces slightly windier conditions along Lundy’s Lane in comparison to existing conditions, wind conditions with the proposed development are nevertheless considered acceptable for public sidewalks and transit stops.



**Neighbouring Existing Surface Parking Lots:** Conditions over the neighbouring existing surface parking lots located from the northeast clockwise to the west of the subject site are predicted to be suitable for a mix of sitting and standing during the summer, becoming suitable for standing, or better, during the winter, with isolated regions suitable for walking to the southeast of the subject site, prior to and following the introduction of the proposed development. The noted conditions are considered acceptable.

Following the introduction of the proposed development, wind conditions over the existing surface parking lot within the subject site are predicted to be suitable for a mix of sitting and standing during the summer, becoming suitable for standing, or better, during the winter, with an isolated region suitable for walking to the northwest of the proposed development. The noted conditions are considered acceptable.

Under the existing massing, conditions over the surface parking within the subject site are predicted to be suitable for sitting during the summer, becoming suitable for standing, or better, during the winter. While the introduction of the proposed development produces slightly windier conditions over the area in comparison to existing conditions, wind conditions under the proposed development are nevertheless considered acceptable.

**Proposed Surface Parking Along Rear Elevation of the Proposed Development:** Wind conditions over the proposed surface parking along the north elevation of the proposed development are predicted to be suitable for standing, or better, throughout the year. The noted conditions are considered acceptable.

**Landscape Amenities:** Wind conditions over the landscape amenities situated nearly central to the subject site and to the east of the proposed development are predicted to be suitable for mostly sitting during the summer, which is considered acceptable.

**Building Access Points:** Owing to the protection of the building façade, wind conditions in the vicinity of the building access points serving the proposed development are predicted to be suitable for sitting during the summer, becoming suitable for standing, or better, during the winter. The noted conditions are considered acceptable.

## 5.2 Wind Safety

Within the context of typical weather patterns, which exclude anomalous localized storm events such as tornadoes and downbursts, no pedestrian areas within or surrounding the subject are expected to experience conditions that could be considered dangerous, as defined in Section 4.4.

## 5.3 Applicability of Results

Pedestrian wind comfort and safety have been quantified for the specific configuration of existing and foreseeable construction around the subject site. Future changes (that is, construction or demolition) of these surroundings may cause changes to the wind effects in two ways, namely: (i) changes beyond the immediate vicinity of the subject site would alter the wind profile approaching the subject site; and (ii) development in proximity to the subject site would cause changes to local flow patterns.

## 6. SUMMARY AND RECOMMENDATIONS

A complete summary of the predicted wind conditions is provided in Section 5 of this report and illustrated in Figures 3A-4B. Based on computer simulations using the CFD technique, meteorological data analysis of the Niagara Falls wind climate, City of Niagara Falls wind comfort and safety criteria, and experience with numerous similar developments, the study concludes the following:

- 1) All grade-level areas within and surrounding the subject site are predicted to experience conditions that are considered acceptable for the intended pedestrian uses throughout the year. Specifically, conditions over surrounding sidewalks, transit stops, neighbouring existing surface parking lots, the landscape amenities, and in the vicinity of building access points, are considered acceptable.
- 2) The foregoing statements and conclusions apply to common weather systems, during which no dangerous wind conditions, as defined in Section 4.4, are expected over the subject site. During extreme weather events, (for example, thunderstorms, tornadoes, and downbursts), pedestrian safety is the main concern. However, these events are generally short-lived and infrequent and there is often sufficient warning for pedestrians to take appropriate cover.

Sincerely,

**Gradient Wind Engineering Inc.**



Omar Rioseco, B.Eng.  
Junior Wind Scientist

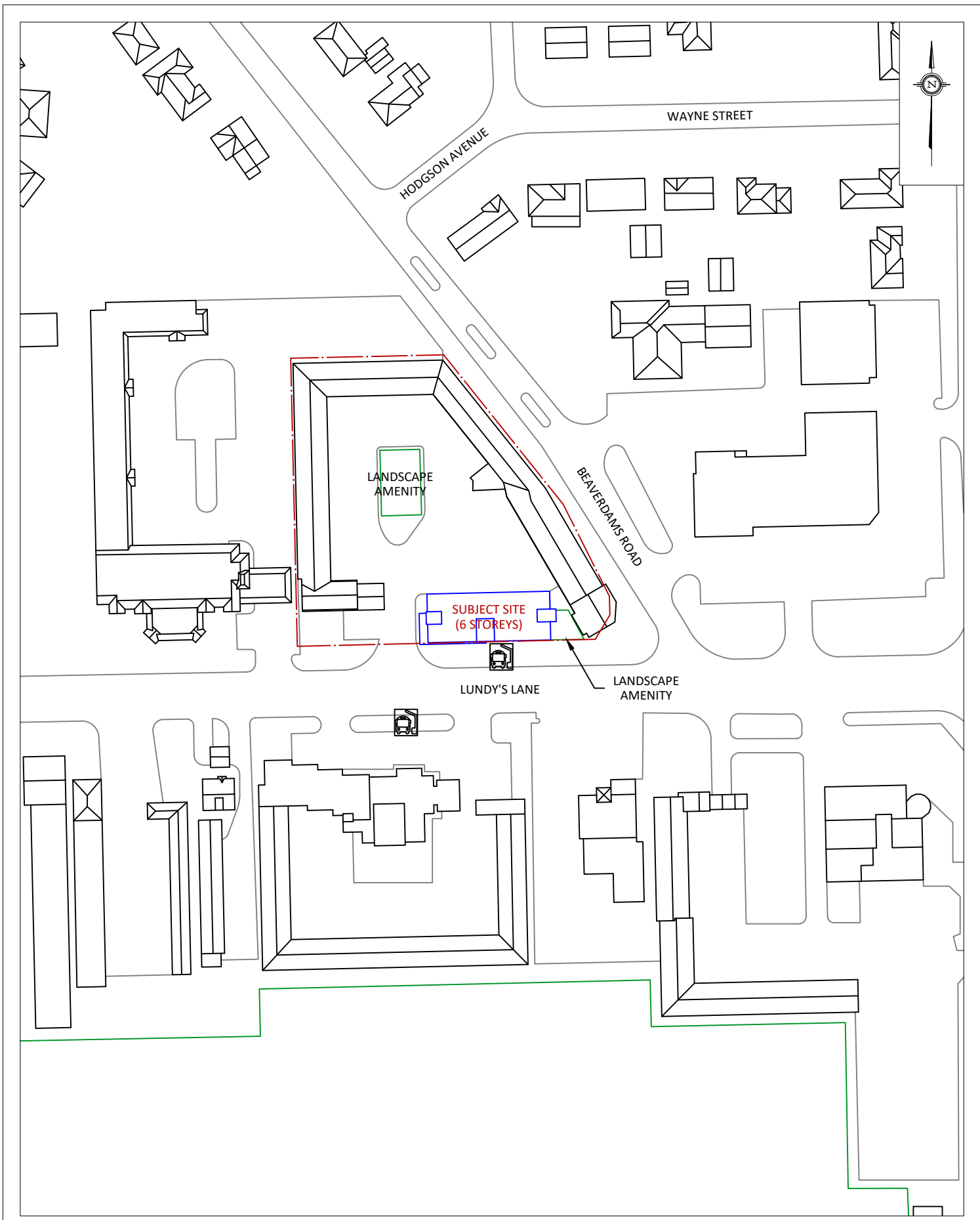


Sunny Kang, B.A.S.  
Project Coordinator

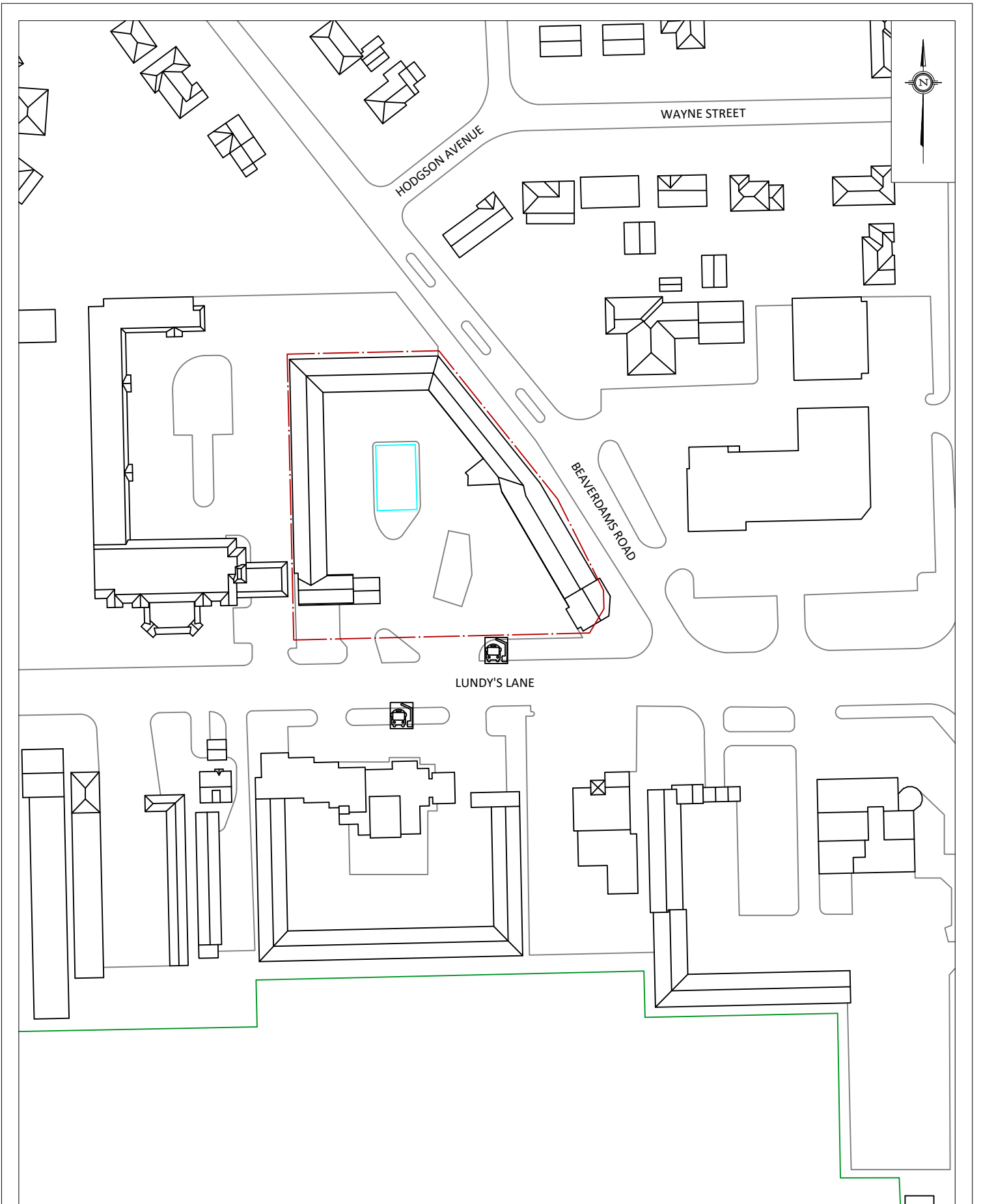


David Huitema, M.Eng., P.Eng.  
CFD Lead Engineer



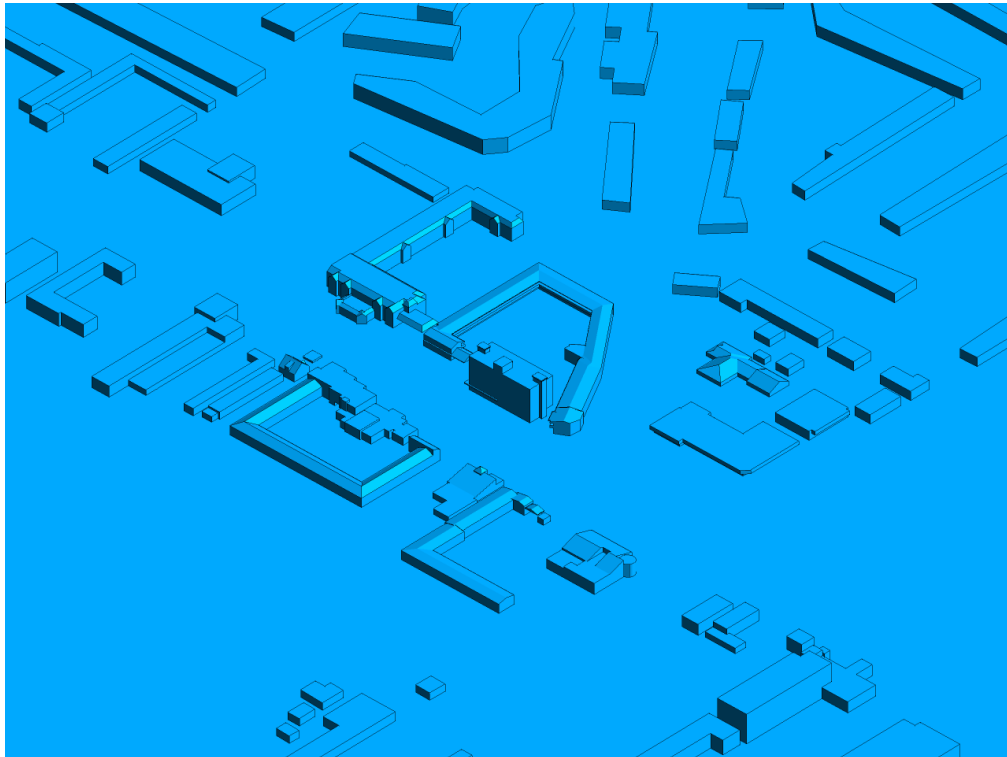


<b>GRADIENTWIND</b> ENGINEERS & SCIENTISTS 127 WALGREEN ROAD, OTTAWA, ON 613 836 0934 • GRADIENTWIND.COM	PROJECT	7701 LUNDY'S LANE, NIAGARA FALLS PEDESTRIAN LEVEL WIND STUDY	DESCRIPTION
	SCALE	1:1500	FIGURE 1A: PROPOSED SITE PLAN AND SURROUNDING CONTEXT
	DATE	JULY 29, 2024	
	DRAWING NO.	24-147-PLW-1A	
	DRAWN BY	S.K.	

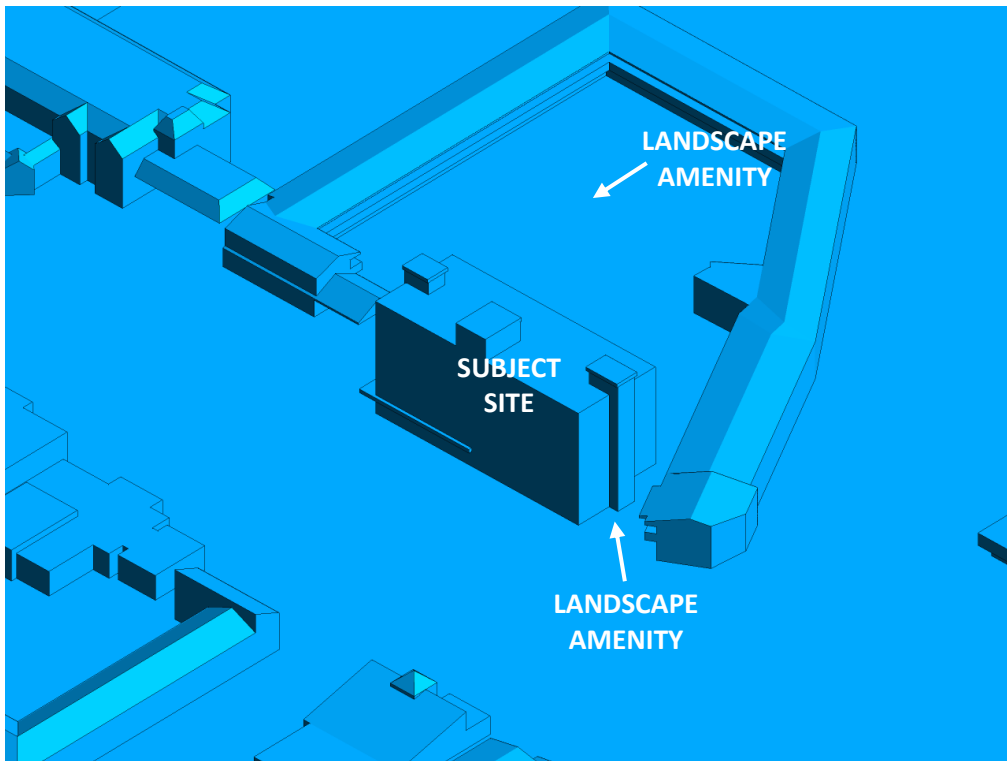


<b>GRADIENTWIND</b> ENGINEERS & SCIENTISTS 127 WALGREEN ROAD, OTTAWA, ON 613 836 0934 • GRADIENTWIND.COM	PROJECT	7701 LUNDY'S LANE, NIAGARA FALLS PEDESTRIAN LEVEL WIND STUDY		DESCRIPTION	FIGURE 1B: EXISTING SITE PLAN AND SURROUNDING CONTEXT
	SCALE	1:1500	DRAWING NO.	24-147-PLW-1B	
	DATE	JULY 29, 2024	DRAWN BY	S.K.	



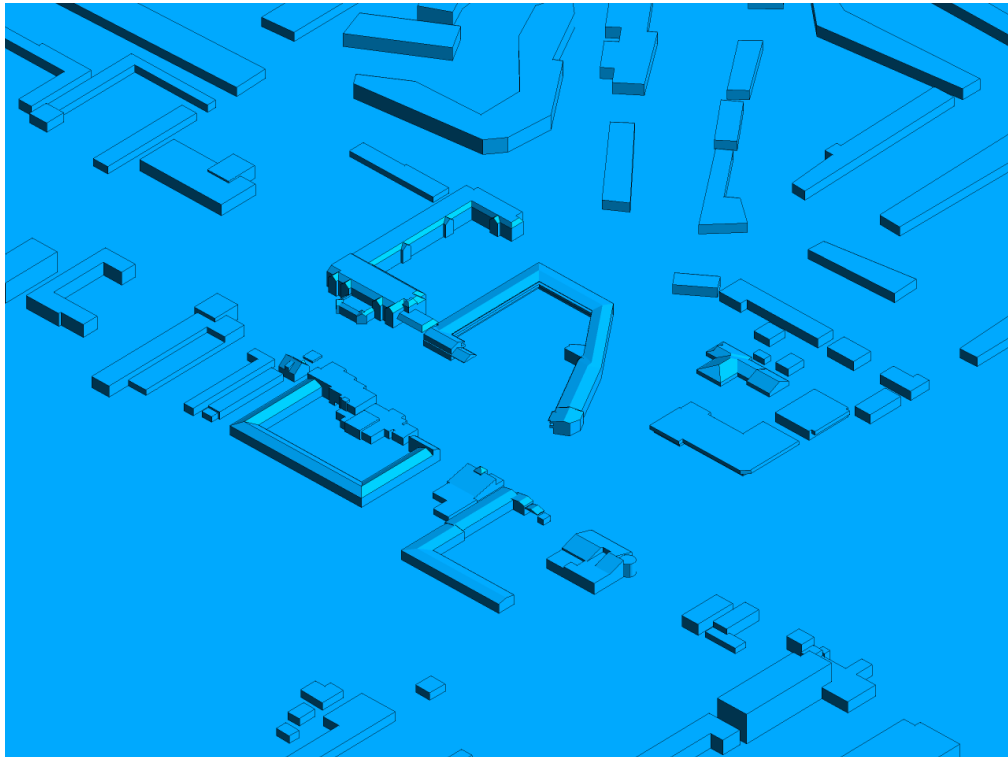


**FIGURE 2A: COMPUTATIONAL MODEL, PROPOSED MASSING, SOUTHEAST PERSPECTIVE**

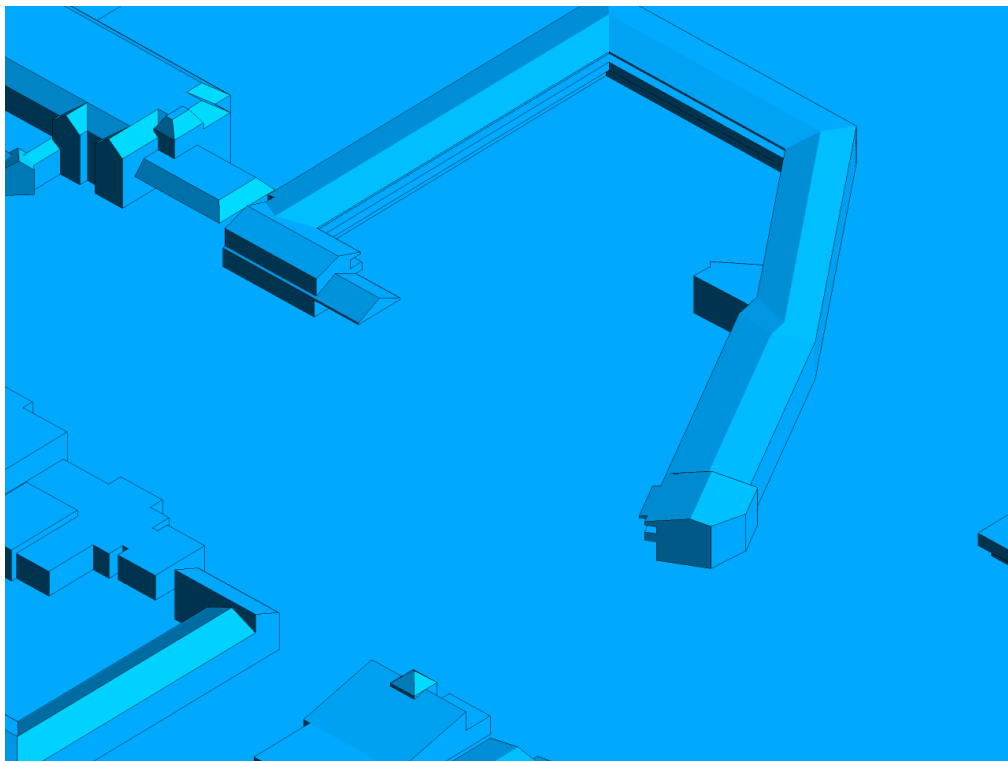


**FIGURE 2B: CLOSE-UP VIEW OF FIGURE 2A**



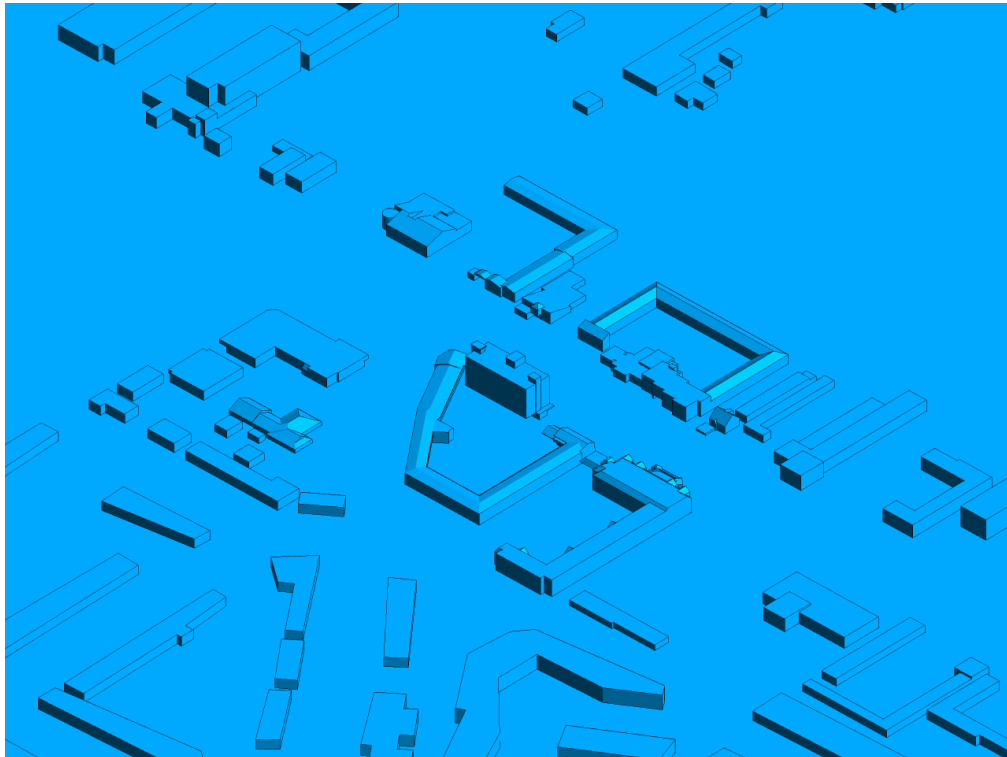


**FIGURE 2C: COMPUTATIONAL MODEL, EXISTING MASSING, SOUTHEAST PERSPECTIVE**

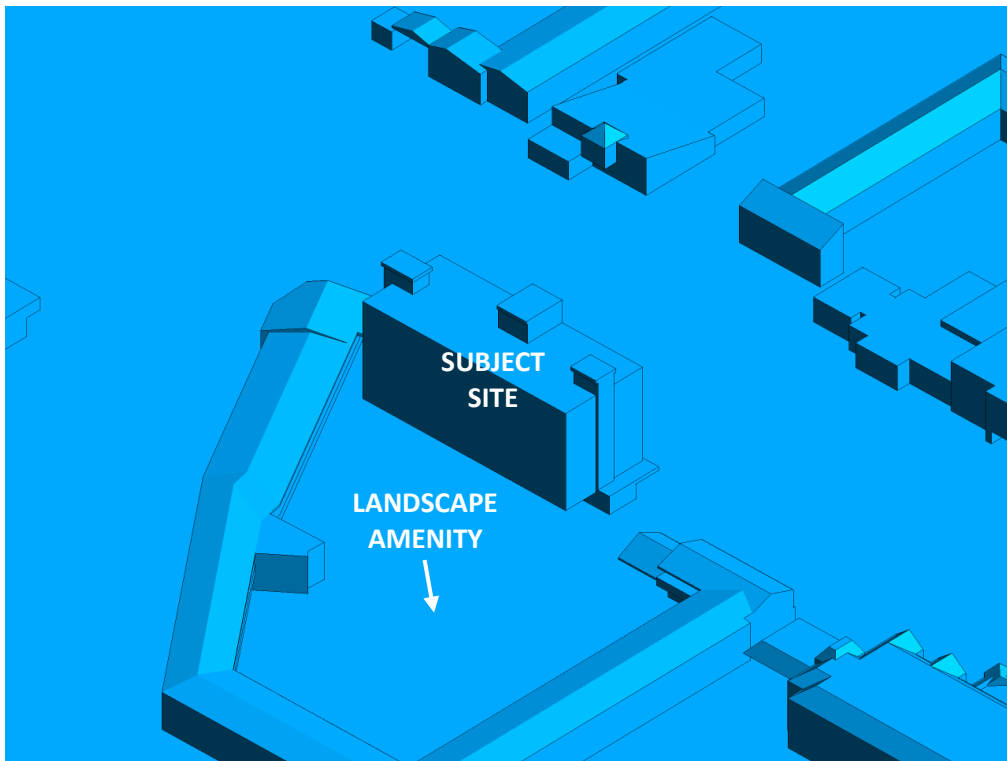


**FIGURE 2D: CLOSE-UP VIEW OF FIGURE 2C**



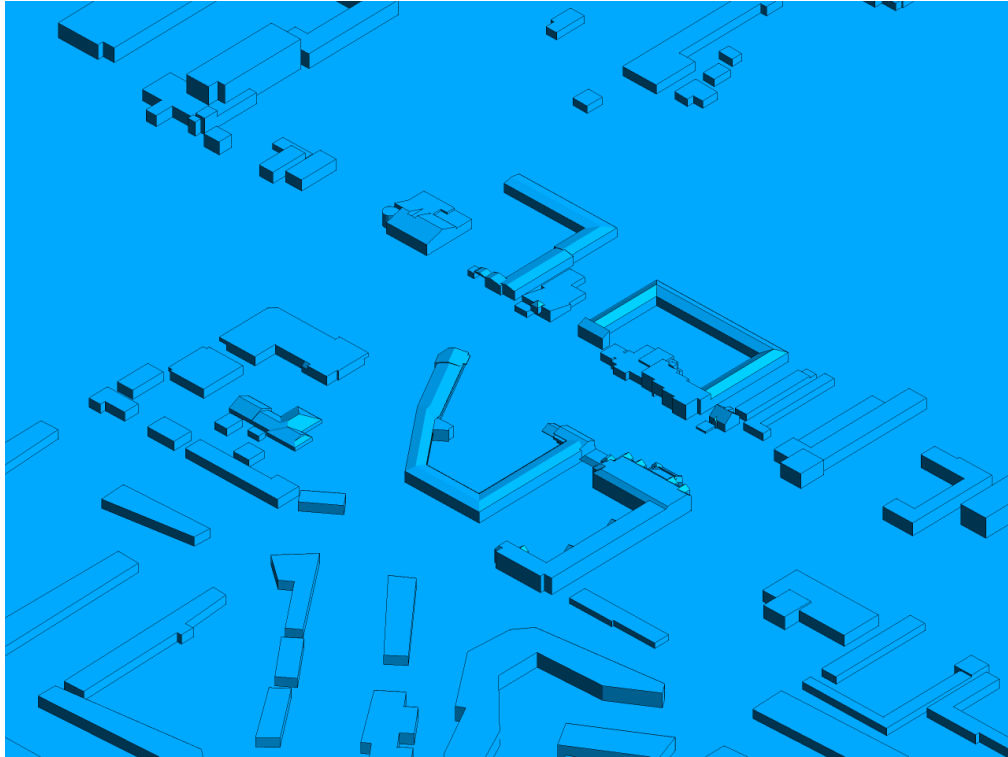


**FIGURE 2E: COMPUTATIONAL MODEL, PROPOSED MASSING, NORTHWEST PERSPECTIVE**

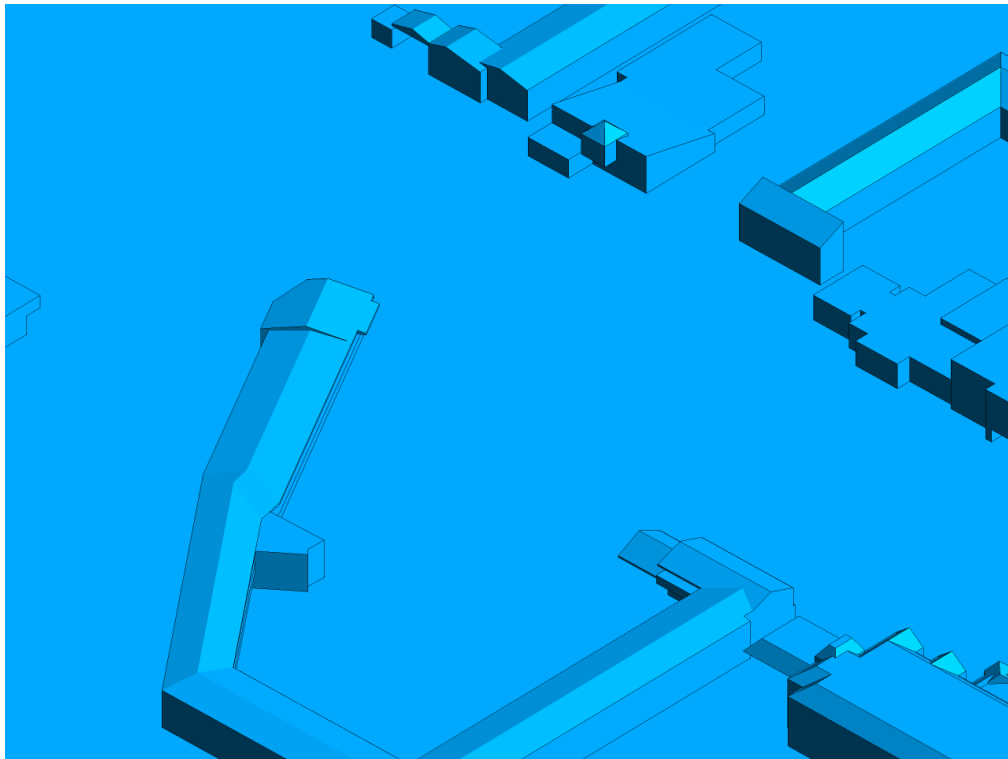


**FIGURE 2F: CLOSE-UP VIEW OF FIGURE 2E**



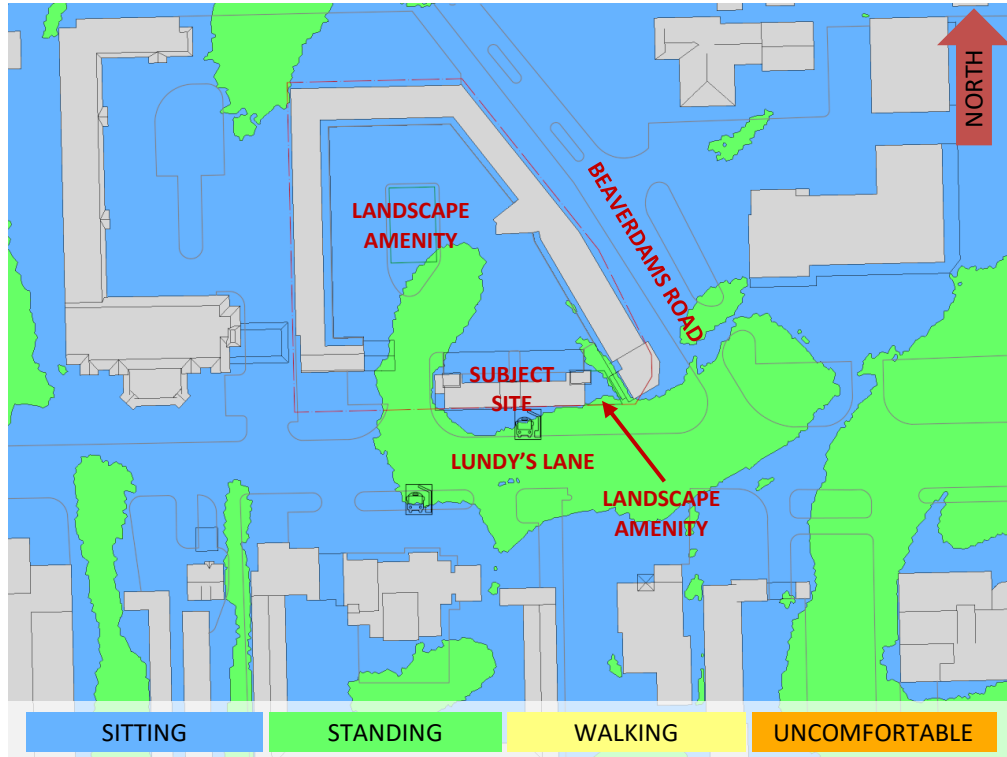


**FIGURE 2G: COMPUTATIONAL MODEL, EXISTING MASSING, NORTHWEST PERSPECTIVE**

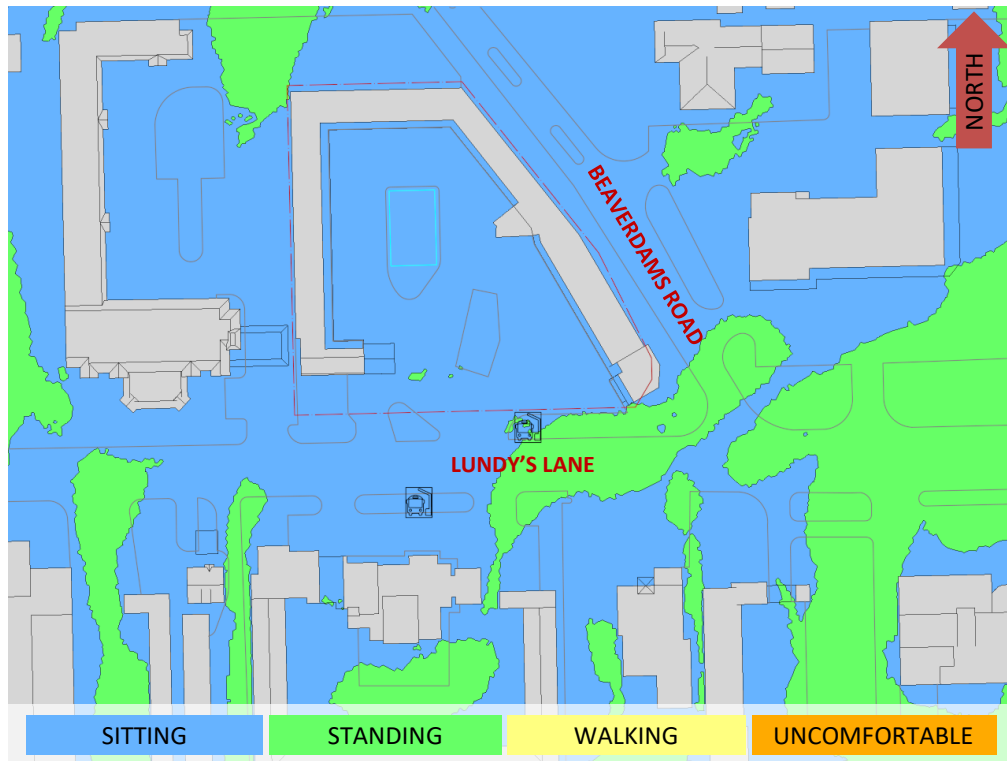


**FIGURE 2H: CLOSE-UP VIEW OF FIGURE 2G**





**FIGURE 3A: SUMMER – PROPOSED MASSING – WIND COMFORT, GRADE LEVEL**



**FIGURE 3B: SUMMER – EXISTING MASSING – WIND COMFORT, GRADE LEVEL**



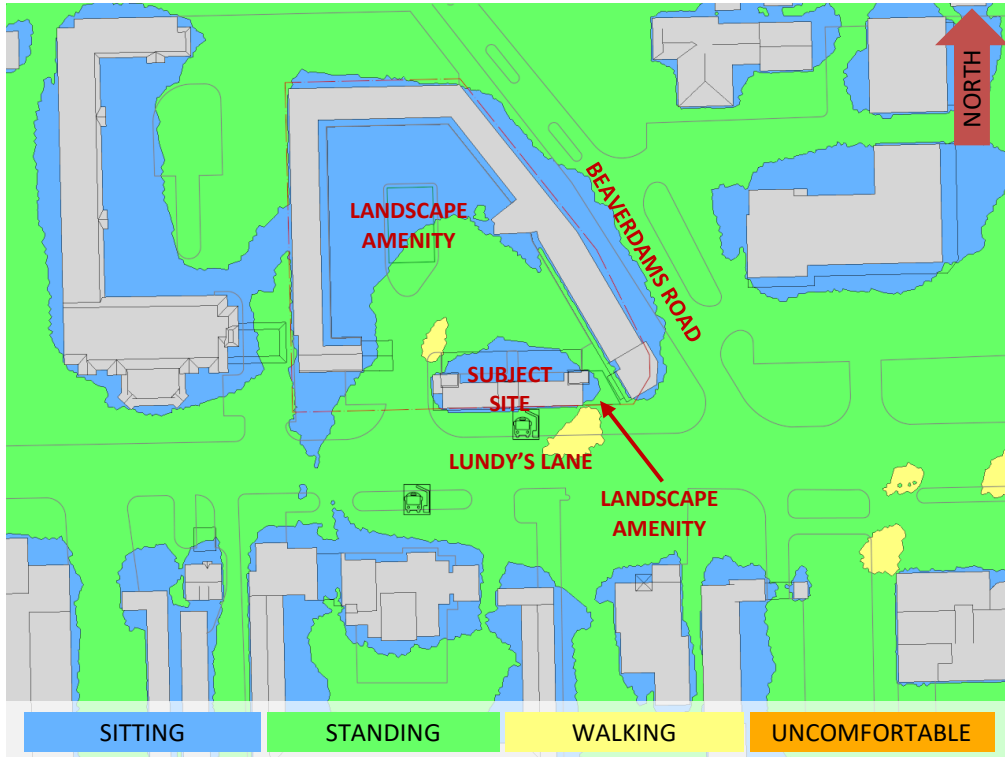


FIGURE 4A: WINTER – PROPOSED MASSING – WIND COMFORT, GRADE LEVEL

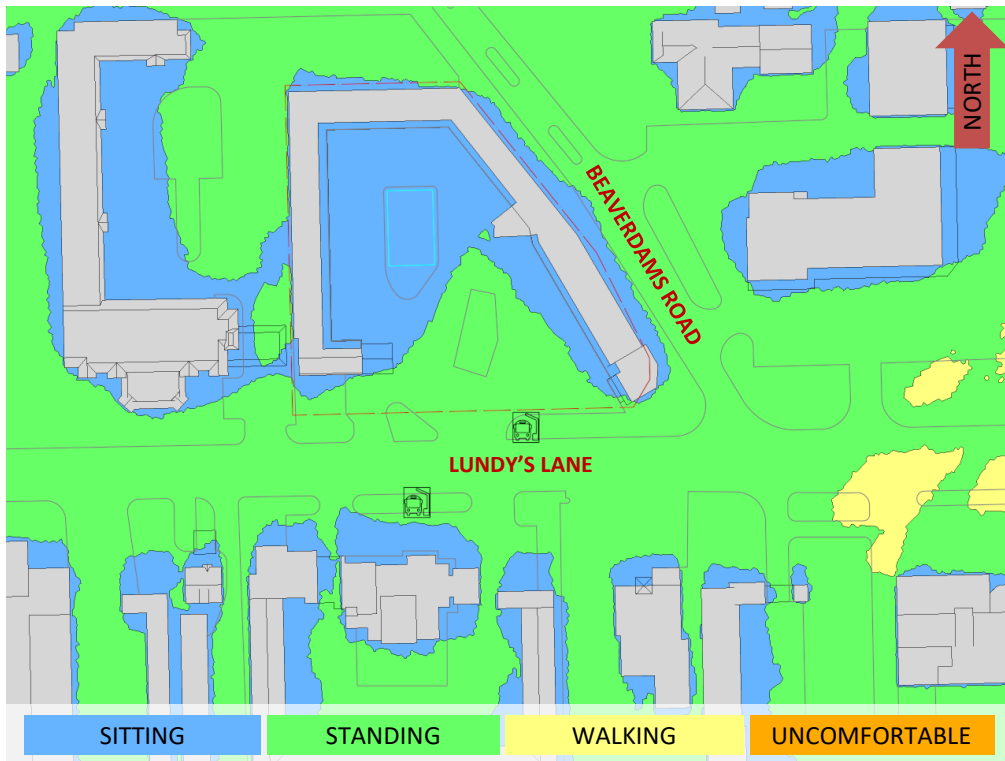
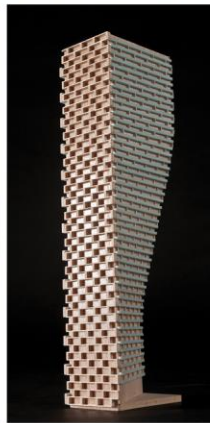


FIGURE 4B: WINTER – EXISTING MASSING – WIND COMFORT, GRADE LEVEL



# GRADIENTWIND

ENGINEERS & SCIENTISTS



## APPENDIX A

### SIMULATION OF THE ATMOSPHERIC BOUNDARY LAYER

## **SIMULATION OF THE ATMOSPHERIC BOUNDARY LAYER**

The atmospheric boundary layer (ABL) is defined by the velocity and turbulence profiles according to industry standard practices. The mean wind profile can be represented, to a good approximation, by a power law relation, Equation (1), giving height above ground versus wind speed [1], [2].

$$U = U_g \left( \frac{Z}{Z_g} \right)^\alpha \quad \text{Equation (1)}$$

where,  $U$  = mean wind speed,  $U_g$  = gradient wind speed,  $Z$  = height above ground,  $Z_g$  = depth of the boundary layer (gradient height), and  $\alpha$  is the power law exponent.

For the model,  $U_g$  is set to 6.5 metres per second (m/s), which approximately corresponds to the 35% mean wind speed for Niagara Falls based on historical climate data and statistical analyses. When the results are normalized by this velocity, they are relatively insensitive to the selection of gradient wind speed.

$Z_g$  is set to 540 m. The selection of gradient height is relatively unimportant, so long as it exceeds the building heights surrounding the subject site. The value has been selected to correspond to our physical wind tunnel reference value.

$\alpha$  is determined based on the upstream exposure of the far-field surroundings (that is, the area that is not captured within the simulation model).



Table 1 presents the values of  $\alpha$  used in this study, while Table 2 presents several reference values of  $\alpha$ . When the upstream exposure of the far-field surroundings is a mixture of multiple types of terrain, the  $\alpha$  values are a weighted average with terrain that is closer to the subject site given greater weight.

**TABLE 1: UPSTREAM EXPOSURE (ALPHA VALUE) VS TRUE WIND DIRECTION**

Wind Direction (Degrees True)	Alpha Value ( $\alpha$ )
0	0.24
22.5	0.24
45	0.24
67.5	0.25
90	0.25
112.5	0.25
135	0.25
157.5	0.25
180	0.24
202.5	0.24
225	0.23
247.5	0.23
270	0.23
292.5	0.22
315	0.22
337.5	0.23

**TABLE 2: DEFINITION OF UPSTREAM EXPOSURE (ALPHA VALUE)**

Upstream Exposure Type	Alpha Value ( $\alpha$ )
Open Water	0.14-0.15
Open Field	0.16-0.19
Light Suburban	0.21-0.24
Heavy Suburban	0.24-0.27
Light Urban	0.28-0.30
Heavy Urban	0.31-0.33

The turbulence model in the computational fluid dynamics (CFD) simulations is a two-equation shear-stress transport (SST) model, and thus the ABL turbulence profile requires that two parameters be defined at the inlet of the domain. The turbulence profile is defined following the recommendations of the Architectural Institute of Japan for flat terrain [3].

$$I(Z) = \begin{cases} 0.1 \left( \frac{Z}{Z_g} \right)^{-\alpha-0.05}, & Z > 10 \text{ m} \\ 0.1 \left( \frac{10}{Z_g} \right)^{-\alpha-0.05}, & Z \leq 10 \text{ m} \end{cases} \quad \text{Equation (2)}$$

$$L_t(Z) = \begin{cases} 100 \text{ m} \sqrt{\frac{Z}{30}}, & Z > 30 \text{ m} \\ 100 \text{ m}, & Z \leq 30 \text{ m} \end{cases} \quad \text{Equation (3)}$$

where,  $I$  = turbulence intensity,  $L_t$  = turbulence length scale,  $Z$  = height above ground, and  $\alpha$  is the power law exponent used for the velocity profile in Equation (1).

Boundary conditions on all other domain boundaries are defined as follows: the ground is a no-slip surface; the side walls of the domain have a symmetry boundary condition; the top of the domain has a specified shear, which maintains a constant wind speed at gradient height; and the outlet has a static pressure boundary condition.

## REFERENCES

- [1] P. Arya, "Chapter 10: Near-neutral Boundary Layers," in *Introduction to Micrometeorology*, San Diego, California, Academic Press, 2001.
- [2] S. A. Hsu, E. A. Meindl and D. B. Gilhousen, "Determining the Power-Law Wind Profile Exponent under Near-neutral Stability Conditions at Sea," vol. 33, no. 6, 1994.
- [3] Y. Tamura, H. Kawai, Y. Uematsu, K. Kondo and T. Okhuma, "Revision of AIJ Recommendations for Wind Loads on Buildings," in *The International Wind Engineering Symposium, IWES 2003*, Taiwan, 2003.