

**SIDE VIEW**

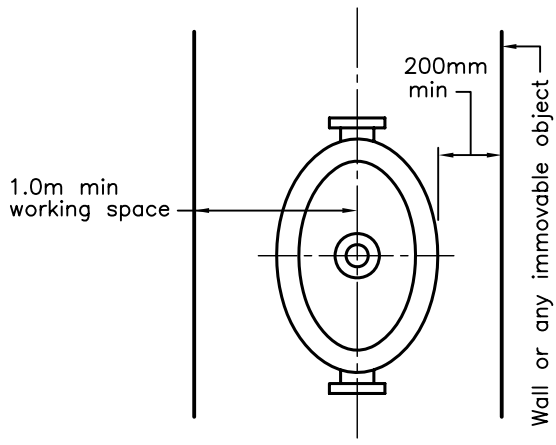

**TOP VIEW OF METER**

**NOTES:**

- A All joints to be restrained. Pipes and valves to be supported.
- B Flanged fittings are required for all compound meters.
- C By-pass line size to be same size as the meter line.
- D Working space at the meter shall be a minimum of 2.0m in height.
- E All dimensions are in metres unless otherwise shown.

ONTARIO PROVINCIAL STANDARD DRAWING

Nov 2006 Rev 1

**PIPING LAYOUT  
FOR WATER METERS  
IN BUILDING WITH BY-PASS**



**OPSD 1107.030**